

HF05 INDUSTRIAL HEAT FLUX SENSOR

The HF05 heat flux sensor is used to measure heat flux in industrial environments. It is covered with a stainless steel cover.

HF05 is protected by a weather proof, all stainless steel enclosure. A thermocouple type K is included.

The output is millivolt signal proportional to the local heat flux and a thermocouple type K for measurement of the absolute temperature. Typical application is in studies of fouling in industrial environments; food processing and fluidised beds.

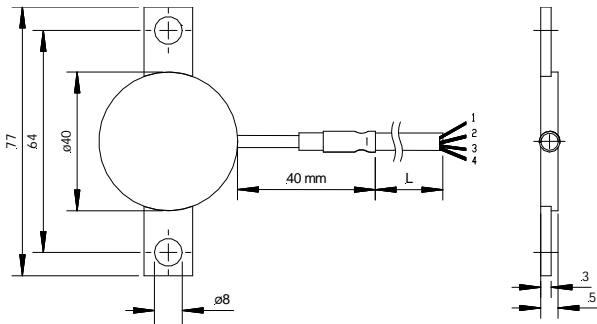
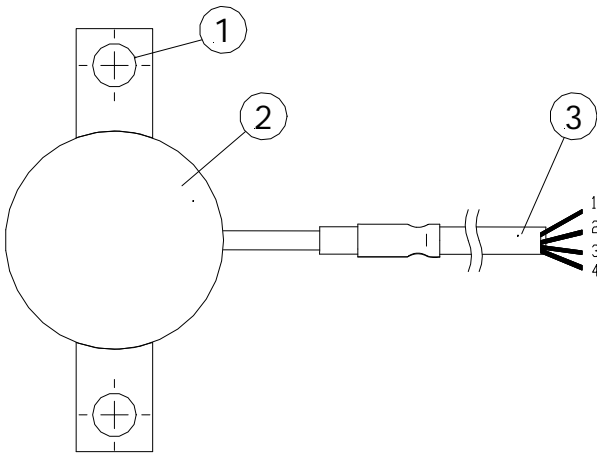

Figure 1 HF05: The heat flux sensor (2) is connected to a stainless steel tube. This tube is again connected to a 3m Teflon cable (3). A flange (1) is situated on both sides of the sensor for mounting. For mounting it is suggested to tack weld M6 thread to the installation shield at a mutual distance of 64 mm. Permanent fixed connection should be glued, for example using silicone glue. Colour code cable: heat flux + red, heat flux - black, TC type K Green thermocouple +, white thermocouple -. Shield is not connected to sensor housing. Serial number engraved on sensor to cable connection. delivered with calibration certificate. Mounting with cable pointed downwards. Bolts holding the sensor should be used for positioning and loose fixation only. No significant mechanical force should be exerted on the flanges.

HF05 SPECIFICATIONS

Sensitivity:	15 mV per W/m ²
Range:	0 to 6 kW/m ²
Temperature:	170 degrees C max
Teflon cable length:	3m (standard, can be extended)

OPTIONS

- Teflon cable extension
- Incorporated heater (extra cable added next to the normal cable with 2 wires for heater connection)
- Metal sheathed cable extension