

# USER MANUAL **AMF / ALF** **SERIES**

Albedometer mounting and levelling fixtures:  
combine 2 pyranometers into 1 albedometer



## Contents

<b>Contents</b>	<b>2</b>
<b>Warning statements</b>	<b>3</b>
<b>Introduction</b>	<b>4</b>
<b>AMF03</b>	<b>5</b>
<b>AMF02</b>	<b>6</b>
<b>ALF01</b>	<b>6</b>
<b>1 Ordering and checking at delivery</b>	<b>8</b>
1.1 Ordering AMF / ALF series albedometer mounting and levelling fixtures	8
1.2 Included items	9
<b>2 Specifications of AMF / ALF series</b>	<b>10</b>
2.1 Specifications of AMF / ALF series albedometer mounting and levelling fixtures	10
2.2 Dimensions of AMF / ALF series	13
<b>3 Installation of AMF / ALF series</b>	<b>14</b>
3.1 Site selection and installation	14
3.2 AMF02	14
3.3 AMF03	17
3.4 ALF01	19
<b>4 Appendices</b>	<b>21</b>
4.1 Appendix on tools for AMF / ALF series	21
4.2 Appendix on spare parts for AMF / ALF series	21

## Warning statements



Mind the safety of the glass domes at each of the mounting and fixation steps of AMF02 and AMF03 installations.

## Introduction

Hukseflux offers a practical range of mounting and levelling fixtures to construct albedometers from its popular pyranometers, and make installation and levelling easy. Albedometers are increasingly popular in bifacial PV module monitoring. AMF03 allows you to combine two SR30-D1 Spectrally Flat Class A pyranometers or two SR15 series Class B pyranometers into one albedometer. AMF02 does so for two SR11 or two SR20 series pyranometers. The modular design facilitates maintenance and calibration of the pyranometers. Both albedometer kits include a mounting fixture and a glare screen.

Hukseflux offers a full range of dedicated, ready-to-use **albedometers** for measuring albedo. Alternatively, with the AMF03 or AMF02 mounting fixture in AMF / ALF series, you may choose to construct albedometers from popular Hukseflux **pyranometers** yourself. ALF01 is a levelling fixture that may be combined with AMF03, AMF02 or SRA series albedometers such as SRA20, and helps levelling the instrument.

Albedo, also called solar reflectance, is defined as the ratio of the reflected to the global radiation. The solar albedo depends on the directional distribution of incoming radiation and on surface properties at ground level. Albedos of typical surfaces range from about 4 % for fresh asphalt, and 15 % for green grass to 90 % for fresh snow.

An albedometer is an instrument composed of two pyranometers, the upfacing one measuring global solar radiation, the downfacing one measuring reflected solar radiation. You can then derive the solar albedo, or solar reflectance and net solar radiation. Albedometers are increasingly popular in bifacial PV module performance monitoring.



**Figure 0.1** AMF02 or AMF03 albedometer kits are used to mount both an up- and a downfacing pyranometer, and construct an albedometer. The image shows the AMF02 mounting fixture and its rod. A glare screen for the downfacing sensor is also included.

### AMF03

You may use one **AMF03** albedometer kit and two model SR30 pyranometers to construct an albedometer of Spectrally Flat Class A, the highest accuracy class according to ISO 9060 (formerly known as 'secondary standard'). AMF03 may also be combined with model SR15 pyranometers to construct a Spectrally Flat Class B albedometer. The modular design facilitates maintenance and calibration of the pyranometers. By taking the instrument apart you can use normal indoor calibration facilities for instrument calibration. SR30-D1 and SR15 series pyranometers (SR15-A1, SR15-D1, SR15-D2A2) are supplied with several outputs; analogue millivolts, 4-20 mA current loop and Modbus over RS-485 are the most commonly used. Likewise, **AMF02** albedometer kit may be used to construct an albedometer out of two SR20(-D2) or SR11 pyranometers.

### Creating an SRA30-D1 or SRA15 series albedometer

AMF03 is easy to use. It allows you to combine two separate SR30-D1 or SR15 series pyranometers, creating one **SRA30-D1** or **SRA15 series** albedometer. All you need are two suitable pyranometers and the AMF03 kit. Mounting instructions and a set of hex keys are delivered with AMF03. AMF03 also includes a glare screen. A glare screen is a metal ring, mounted on the downfacing sensor. At solar elevations of  $< 5^\circ$ , when the sun is just above the horizon, the glare screen prevents that direct solar radiation is measured by the downfacing sensor. This is important, because it would lead to unrealistic albedo measurements. Modern data quality assurance can also attain the data quality by calculating solar elevation and rejecting any data at solar elevations below a certain value, for example  $< 10^\circ$ .

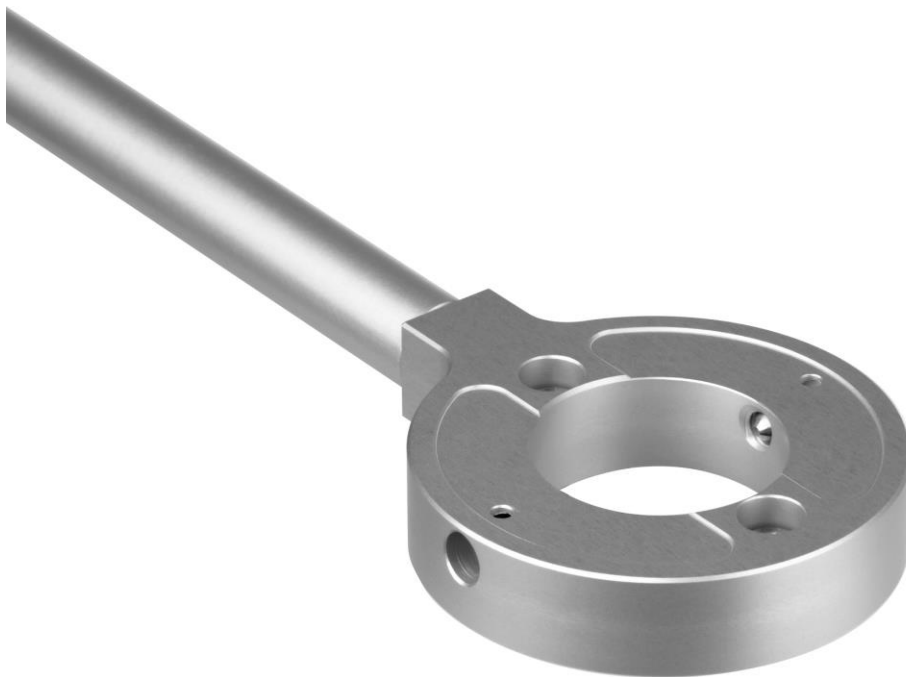

**Figure 0.2** AMF03 mounting fixture and its rod. A glare screen for the downfacing sensor is also included in the AMF03 albedometer mounting kit.

### AMF02

AMF02 is easy to use as well. It allows you to combine two separate SR11 or SR20(-D2) pyranometers into one albedometer. Mounting instructions and a set of hex keys are delivered with AMF02. AMF02 also includes a glare screen.

### ALF01

**ALF01** is a levelling tool that can be used with AMF03, AMF02 or SRA series albedometers such as SRA20 to easily level the instrument. ALF01 is mounted on a 1 inch outer diameter crossarm, and can be rotated around the tube axis for 360 ° as well as tilted over  $\pm 2^\circ$ .



**Figure 0.3** ALF01 albedometer levelling tool, can be rotated around the axis of the crossarm to which it is connected, and tilted over  $\pm 2^\circ$ .



**Figure 0.4** Installation with AMF03, two SR30-D1 pyranometers, and ALF01 levelling fixture

Suggested use for AMF series:

- PV monitoring with bifacial solar modules
- high-accuracy meteorological observations
- building physics, roof reflectance studies
- extreme climates (tropical / polar)



**Figure 0.5** The end result using AMF03 and two SR30-D1 pyranometers: an SRA30-D1 albedometer ready for measuring

#### Example: AMF03 combined with 2 SR30-D1's

SRA30-D1 albedometer consists of two identical pyranometers model SR30-D1, one facing up, one facing down. The two sensors are delivered with one AMF03 fixture with rod for mounting purposes. A glare screen is part of the AMF03 delivery too. The user assembles these modular components into SRA30-D1 albedometer. A mounting and fixation instruction is included with AMF03. Levelling and mounting may be completed by using ALF01 levelling fixture and **CMF01** crossarm mounting fixture to mount the crossarm to a mast.

Please also refer to the user manual of your pyranometer / albedometer for a proper installation of that particular instrument with AMF / ALF series albedometer mounting and levelling fixtures. The instrument should be used in accordance with the recommended practices of ISO, IEC, WMO and ASTM.

See also:

- **SRA30-D1** digital Spectrally Flat Class A albedometer with heating and ventilation
- **SRA15 series** Spectrally Flat Class B albedometers
- **SRA20-D2** digital Spectrally Flat Class A albedometer
- **SRA11** Spectrally Flat Class B albedometer
- **SRA01** Spectrally Flat Class C albedometer
- **SR30-D1** digital Spectrally Flat Class A pyranometer with heating and ventilation
- **SR15 series** analogue and digital Spectrally Flat Class B pyranometers
- **SR20-D2** digital pyranometer, **SR20** pyranometer and **SR11** pyranometer
- alternative instrument: **NR01** 4-component net-radiometer for solar and longwave radiation balance
- **CMF01** crossarm mounting fixture

# 1 Ordering and checking at delivery

## 1.1 Ordering AMF / ALF series albedometer mounting and levelling fixtures

AMF / ALF series is a range of accessories for use with pyranometers and albedometers. The ordering codes of the different versions in AMF / ALF series are AMF01, AMF02, AMF03 and ALF01.

**Table 1.1.1** *Overview of versions in AMF / ALF series*

<b>VERSIONS OF AMF / ALF SERIES</b>	
AMF01	albedometer mounting kit for 2 x LP02 / SR03 pyranometers
AMF02	albedometer mounting kit for 2 x SR20 / SR11 pyranometers
AMF03	albedometer mounting kit for 2 x SR30 / SR15 pyranometers
ALF01	albedometer levelling fixture for AMF02, AMF03 and SRA series albedometers



## 1.2 Included items

Arriving at the customer, the delivery should include:

- AMF01 albedometer mounting fixture including:
  - 1 x AMF01 fixture with rod
  
- AMF02 albedometer mounting fixture including:
  - 1 x glare screen
  - 1 x AMF02 fixture with rod
  - 2 x o-ring
  - 1 x conical positioner
  - 2 x plug (pre-mounted)
  - 2 x M5x12 socket head cap screw
  - 1 x M6x8 socket head cap screw
  - 2 x M6x12 set screw (pre-mounted)
  - 1 x mounting and fixation instruction sheet
  
- AMF03 albedometer mounting fixture including:
  - 1 x glare screen
  - 1 x AMF03 fixture with rod
  - 1 x conical positioner
  - 2 x M5x12 socket head cap screw
  - 1 x M6x8 socket head cap screw
  - 2 x M8x12 set screw (pre-mounted)
  - 1 x mounting and fixation instruction sheet
  
- ALF01 levelling fixture including:
  - 1 x levelling fixture

## 2 Specifications of AMF / ALF series

### 2.1 Specifications of AMF / ALF series albedometer mounting and levelling fixtures

AMF / ALF series is a range of accessories for use with pyranometers and albedometers.

AMF02 is an albedometer mounting kit for 2 x SR20 / SR11 pyranometers. It allows you to combine two separate SR11 or SR20(-D2) pyranometers into one albedometer yourself. Mounting instructions and a set of hex keys are delivered with AMF02. AMF02 also includes a glare screen. AMF02 can only be used in combination with two suitable pyranometers.

AMF03 is an albedometer mounting kit for 2 x SR30 / SR15 pyranometers. It allows you to combine two separate SR30-D1 or SR15 series pyranometers into one albedometer yourself. Mounting instructions and a set of hex keys are delivered with AMF03. AMF03 also includes a glare screen. AMF03 can only be used in combination with two suitable pyranometers.

ALF01 is a levelling tool that can be used with AMF02, AMF03 or SRA series albedometers to easily level the instrument.

Please also refer to your pyranometer or albedometer user manual for a proper installation of that particular instrument with AMF / ALF series mounting and levelling fixtures. The instrument should be used in accordance with the recommended practices of ISO, IEC, WMO and ASTM.

**Table 2.1.1** *Specifications of AMF / ALF series (continued on next pages)*

<b>AMF02 GENERAL SPECIFICATIONS</b>	
Product type	bracket
Purpose	construction of an albedometer when combined with 2 pyranometers
Instrument compatibility	2 x SR20, SR20-D2 or SR11
Measurand	global solar radiation and reflected solar radiation
Optional measurand	albedo or solar reflectance
Optional measurand	net solar radiation
Material	anodised aluminium (bolts made of stainless steel)
Rated operating temperature	-40 to +80 °C
Rod diameter	15 x 10 <sup>-3</sup> m
Included parts	1 x glare screen
	1 x AMF02 fixture with rod
	2 x o-ring
	1 x conical positioner
	2 x plug (pre-mounted)
	2 x M5x12 socket head cap screw

**Table 2.1.1** Specifications of AMF / ALF series (started on previous page)

<b>AMF02 GENERAL SPECIFICATIONS CONTINUED</b>	
	1 x M6x8 socket head cap screw
	2 x M6x12 set screw (pre-mounted)
	1 x mounting and fixation instruction sheet
Required tools (included)	hex key no. 2 (2 mm)
	hex key no. 3 (3 mm)
	hex key no. 4 (4 mm)
	hex key no. 5 (5 mm)
<b>AMF02 TRANSPORT</b>	
Gross weight	0.6 kg
Net weight	0.3 kg
Packaging	box of (150 x 150 x 450) mm
<b>AMF03 GENERAL SPECIFICATIONS</b>	
Product type	bracket
Purpose	construction of an albedometer when combined with 2 pyranometers
Instrument compatibility	2 x SR30-D1, SR15-A1, SR15-D1 or SR15-D2A2
Measurand	global solar radiation and reflected solar radiation
Optional measurand	albedo or solar reflectance
Optional measurand	net solar radiation
Material	anodised aluminium (bolts made of stainless steel)
Rated operating temperature	-40 to +80 °C
Rod diameter	15 x 10 <sup>-3</sup> m
Included parts	1 x glare screen
	1 x AMF03 fixture with rod
	1 x conical positioner
	2 x M5x12 socket head cap screw
	1 x M6x8 socket head cap screw
	2 x M8x12 set screw (pre-mounted)
	1 x mounting and fixation instruction sheet
Required tools (included)	hex key no. 2 (2 mm)
	hex key no. 4 (4 mm)
<b>AMF03 TRANSPORT</b>	
Gross weight	0.6 kg
Net weight	0.3 kg
Packaging	bubble wrap pouch of (100 x 60 x 500) mm
<b>ALF01 GENERAL SPECIFICATIONS</b>	
Instrument compatibility	AMF02 or AMF03 albedometer mounting fixture, or SRA series albedometers: SRA30-D1, SRA15-A1, SRA15-D1, SRA15-D2A2, SRA20, SRA20-D2, SRA11, SRA01
Tilt angle adjustment range	± 2 °
Rotation able adjustment range	360 °
Crossarm outer diameter	1 inch
Rod diameter	15 x 10 <sup>-3</sup> m
Rated operating temperature	-40 to +80 °C

**Table 2.1.1** *Specifications of AMF / ALF series (started on previous pages)*

<b>ALF01 GENERAL SPECIFICATIONS CONTINUED</b>	
Material	anodised aluminium (bolts made of stainless steel)
Included parts	ALF01 levelling fixture, including 6 pre-mounted bolts
Required tools (not included)	hex key no. 4 (4 mm)
<b>ALF01 TRANSPORT</b>	
Gross weight	0.3 kg
Net weight	0.3 kg
Packaging	bubble wrap pouch of (100 x 65 x 65) mm

## 2.2 Dimensions of AMF / ALF series

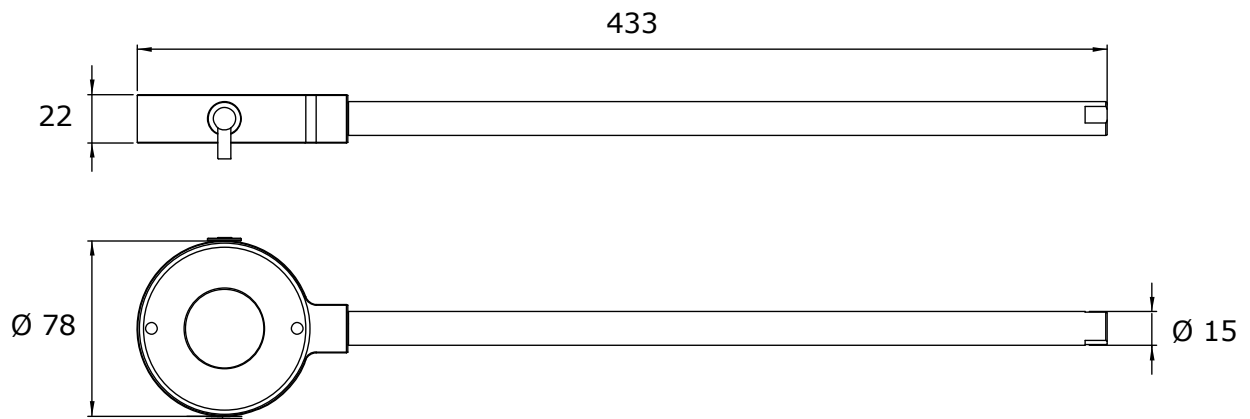

**Figure 2.2.1** Dimensions of AMF02 in  $10^{-3}$  m.

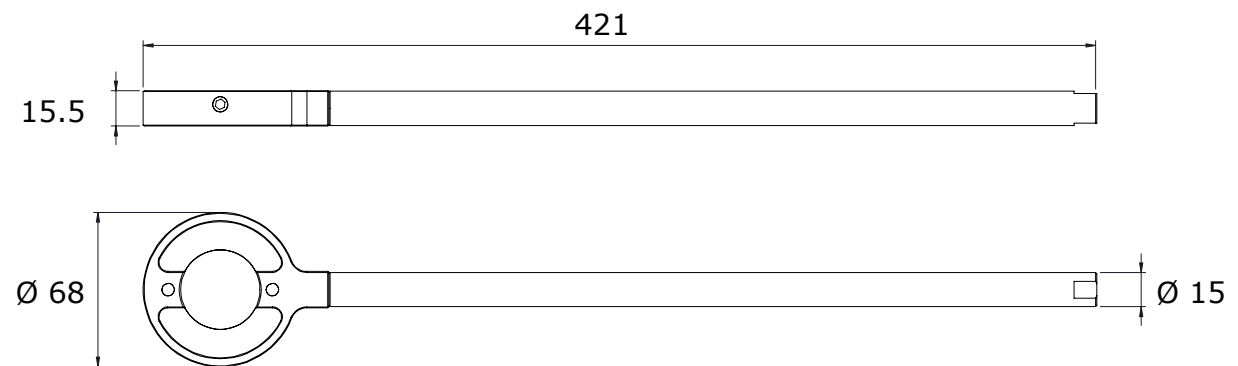

**Figure 2.2.2** Dimensions of AMF03 in  $10^{-3}$  m.

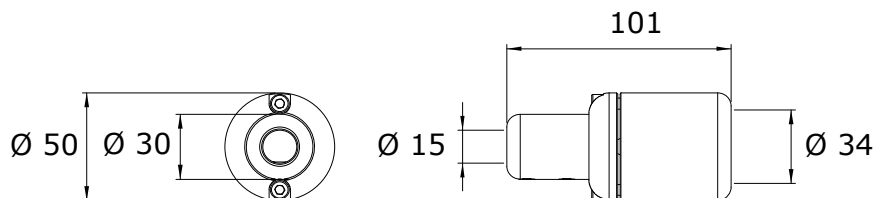

**Figure 2.2.3** Dimensions of ALF01 in  $10^{-3}$  m.

## 3 Installation of AMF / ALF series

### 3.1 Site selection and installation

Please refer to the user manual of your pyranometer or albedometer for a proper installation of that particular instrument with AMF / ALF series mounting and levelling fixtures. The instrument should be used in accordance with the recommended practices of ISO, IEC, WMO and ASTM.

### 3.2 AMF02

AMF02 is an albedometer mounting kit for 2 x SR20 / SR11 pyranometers. It allows you to combine two separate SR11 or SR20(-D2) pyranometers into one albedometer yourself.

Please follow the instructions below for either 2 x SR11 or 2 x SR20(-D2), with AMF02. Mind the safety of the glass domes at each step!

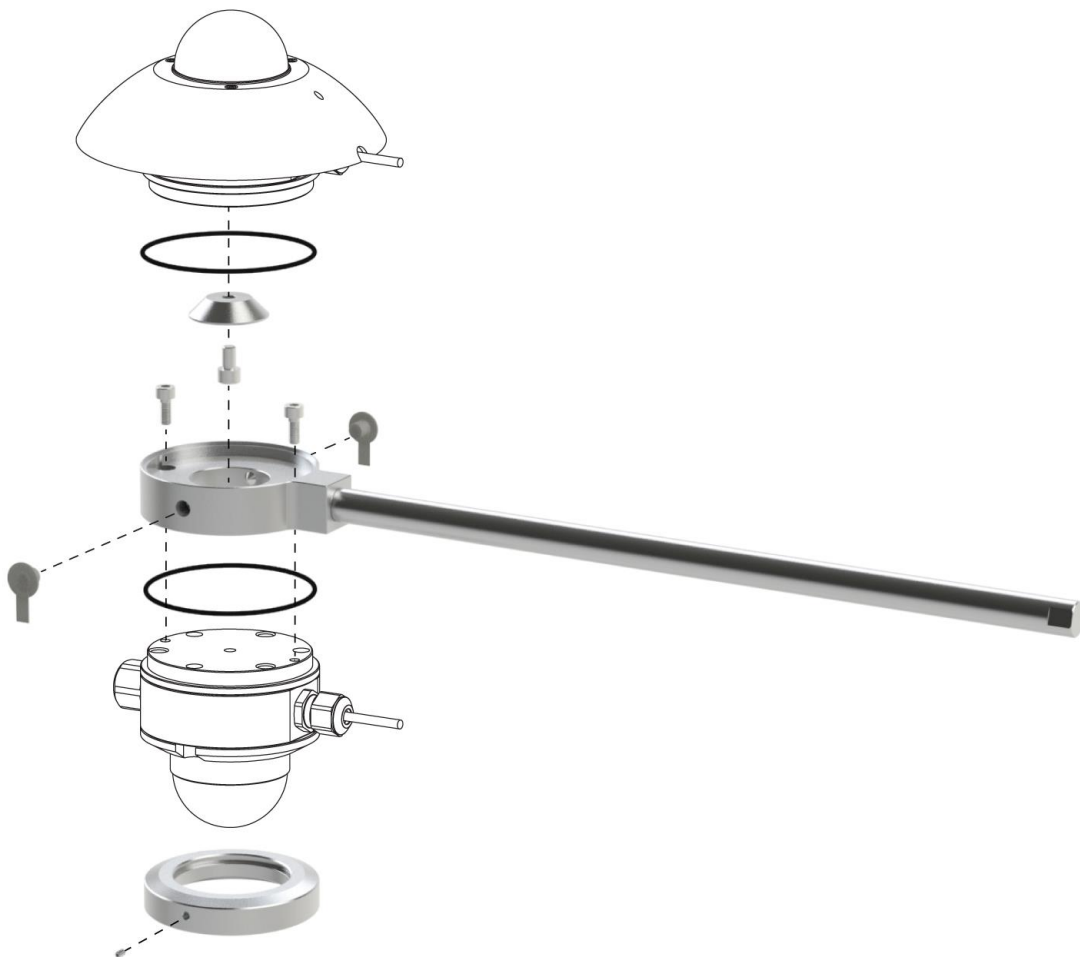

**Figure 3.2.1** AMF02 with 2 x SR11, mounting and fixation steps 1 - 8

**AMF02 mounting and fixation steps 1 to 8:**

1. remove feet of both sensors.
2. remove sun screen from downfacing sensor.
3. install glare screen on downfacing sensor.
4. remove plugs from fixture.
5. mount the downward facing SRxx (sensor with glare screen) to the fixture with rod using two M5x12 screws. Ensure that one o-ring is positioned properly between sensor and fixture.
6. affix the conical positioner to the upward facing SRxx (sensor with sun screen) using one M6x8 screw.
7. mount the upward facing SRxx (with its sun screen and conical positioner) to the fixture. Ensure that one o-ring is positioned properly between sensor and fixture. Affix with the pre-mounted M6 setscrews.
8. place plugs. Mounting SRxx is complete.

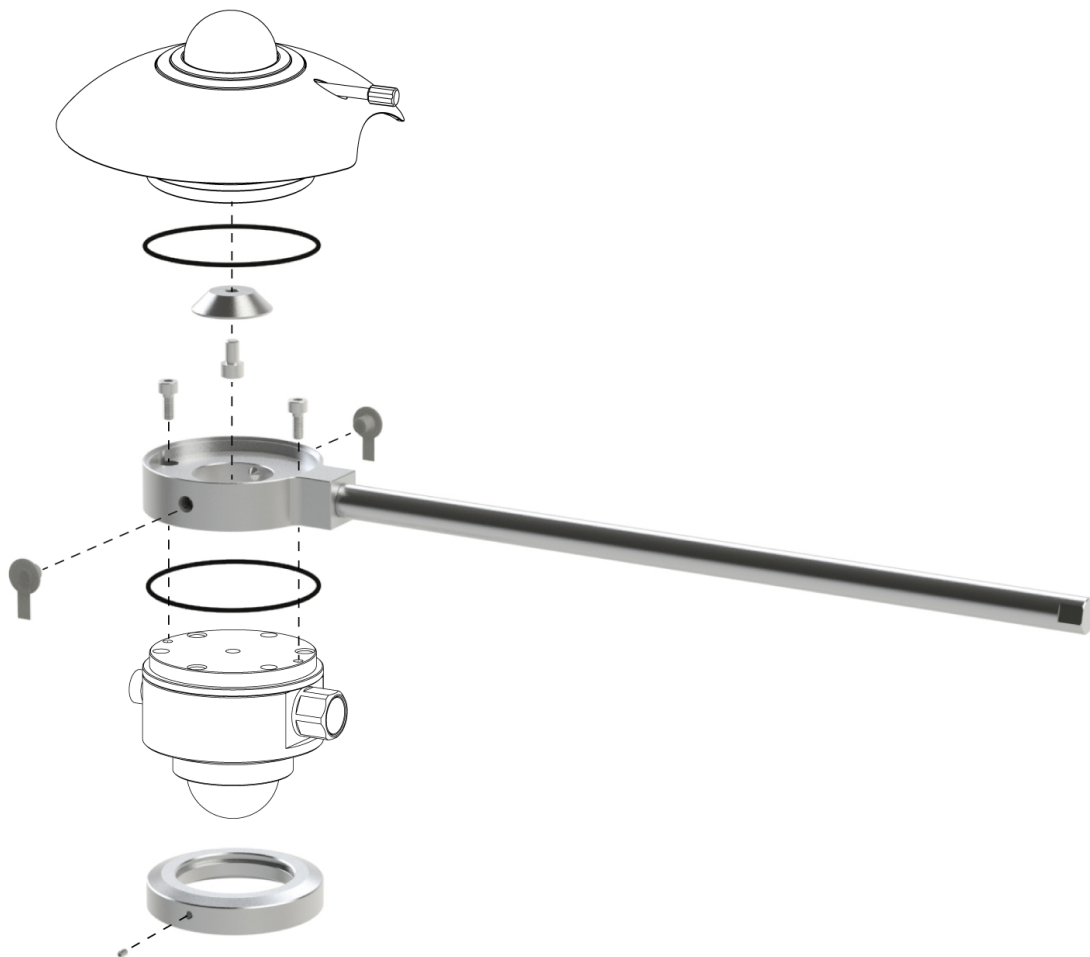

**Figure 3.2.2** AMF02 with 2 x SR20(-D2), mounting and fixation steps 1 – 8



**Figure 3.2.3** AMF02 with 2 x SR11



**Figure 3.2.4** AMF02 with 2 x SR20(-D2)



### 3.3 AMF03

AMF03 is an albedometer mounting kit for 2 x SR30 / SR15 pyranometers. It allows you to combine two separate SR30-D1 or SR15 series pyranometers into one albedometer yourself.

Please follow the instructions below for either 2 x SR30-D1 or 2 x SR15 series, with AMF03. Mind the safety of the glass domes at each step!



**Figure 3.3.1** AMF03 with 2 x SR30 / SR15, mounting and fixation steps 1 – 7

**AMF03 mounting and fixation steps 1 to 7:**

1. Remove sensor feet of both sensors.
2. Remove sun screen from downfacing sensor.
3. Install glare screen on downfacing sensor using 2 mm hex key.
4. Mount the downward facing SR30 / SR15 (sensor with glare screen) to the fixture with rod using two M5x12 screws and 4 mm hex key.
5. Affix the conical positioner to the upward facing SR30 / SR15 (sensor with sun screen) using one M6x8 screw and 4 mm hex key.
6. Mount the upward facing SR30 / SR15 (with its sun screen and conical positioner) to the fixture. Affix with the pre-mounted M8 screws using 4 mm hex key.
7. Mounting SRA30-D1 or SRA15 series is complete.

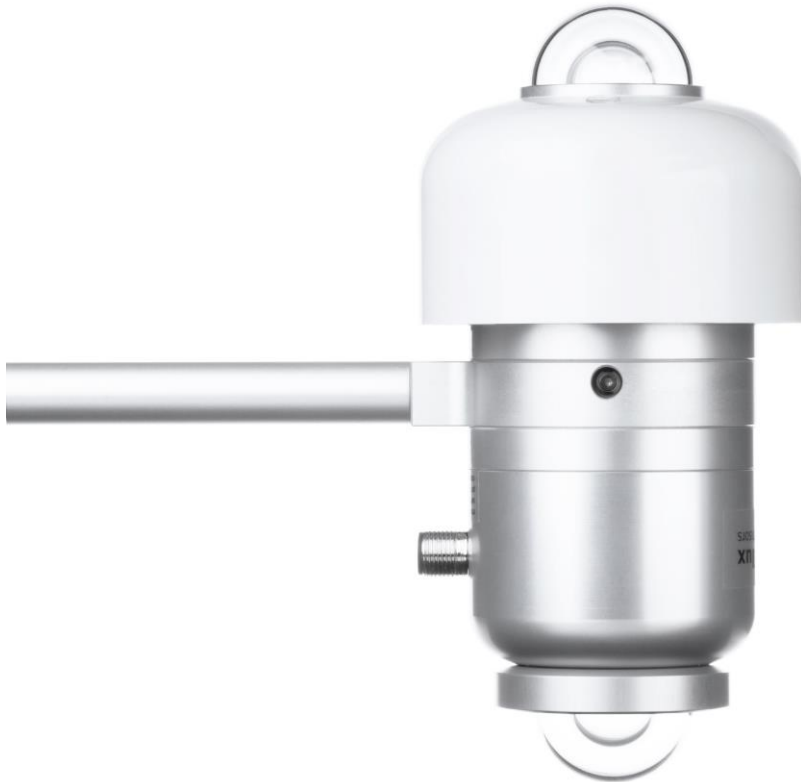
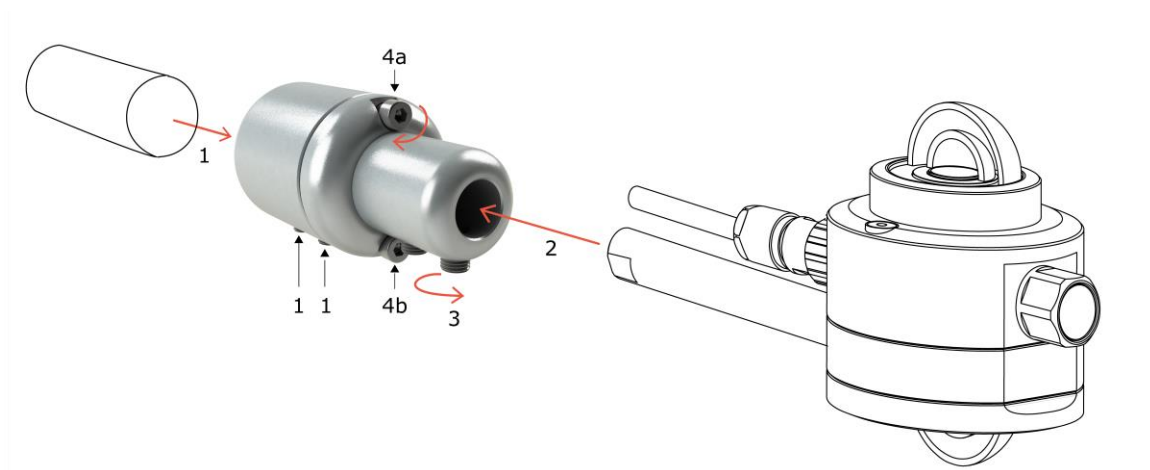

**Figure 3.3.2** *AMF03 with 2 x SR30 / SR15*

### 3.4 ALF01

ALF01 is an albedometer levelling tool that can be used with AMF02, AMF03 or SRA series albedometers to easily level the instrument.

Please follow the instructions below.



**Figure 3.4.1** ALF01 mounting and levelling instructions, steps 1 – 4

#### ALF01 mounting and levelling steps 1 to 4:

1. mount ALF01 onto the 1 inch crossarm and tighten using the 2 bolts.
2. slide the AMF02 or SRA series rod through the ALF01 fixture.
3. level the albedometer sensor in the xy-direction (rotation around the tube axis), and tighten the AMF02 / SRA rod with the 2 designated bolts.
4. level the albedometer sensor in the z-direction (tilting) using the 2 bolts on ALF01:
  - 4a. first position with the top bolt.
  - 4b. lock position with the lower bolt.

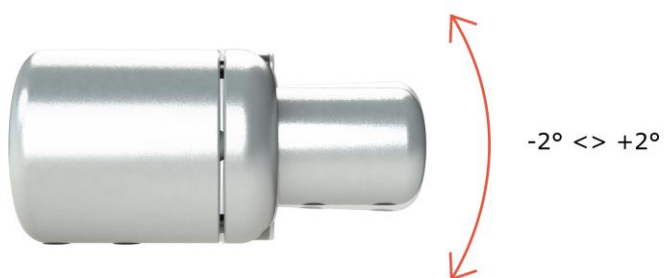

**Figure 3.4.2** ALF01 allows a tilt angle adjustment range in the z-direction of  $\pm 2^\circ$



**Figure 3.4.3** Installation of an albedometer mounted with AMF02 albedometer mounting fixture and levelled with ALF01 albedometer levelling fixture. The crossarm mounting fixture, connecting the cross arm to a vertical mast is CMF01

## 4 Appendices

### 4.1 Appendix on tools for AMF / ALF series

**Table 4.1.1** *Specifications of tools for AMF02, AMF03 and ALF01*

tooling required for AMF02	hex key no. 2 (2 mm)
	hex key no. 3 (3 mm)
	hex key no. 4 (4 mm)
	hex key no. 5 (5 mm)
tooling required for AMF03	hex key no. 2 (2 mm)
	hex key no. 4 (4 mm)
tooling required for ALF01	hex key no. 4 (4 mm)

### 4.2 Appendix on spare parts for AMF / ALF series

- AMF02 glare screen
- AMF02 fixture with rod
- AMF03 glare screen
- AMF03 fixture with rod
- ALF01 levelling fixture



