

USER MANUAL HF03-LI 19

Portable heat flux sensor
with read-out unit / datalogger



Warning statements



HF03-LI19 does not carry an EC type examination certificate (ATEX).



HF03 is suitable for use during an exposure interval of 10 min and heat flux up to $10 \times 10^3 \text{ W/m}^2$. LI19 is suitable for exposure up to $2 \times 10^3 \text{ W/m}^2$.



Software supplied with the instrument might not be the latest version. Download the latest version from www.hukseflux.com/page/downloads.



Switch off HF03-LI19 after use, take spare batteries with you.



Hukseflux performs traceable calibrations and is certified according to ISO 9001, but is not an ISO 17025 accredited calibration laboratory.

Contents

Warning statements	2
Contents	3
List of symbols	4
Introduction	5
1 Ordering and checking at delivery	8
1.1 Ordering HF03-LI19	8
1.2 Included items	8
1.3 Latest software	8
1.4 Quick instrument functionality check	9
2 Instrument principle and theory	10
3 Specifications of HF03-LI 19	11
4 Installation of HF03-LI 19	14
4.1 Electrical connection	14
4.2 Software installation on the PC	14
5 Recommended practices for use	15
5.1 Short user guide	15
5.2 Directions for measurement	16
5.3 Battery replacement	16
5.4 The LI19 user interface on PC	17
6 Maintenance and trouble shooting	19
6.1 Recommended maintenance and quality assurance	19
6.2 Trouble shooting	20
6.3 Recoating / repainting of sensor surfaces	20
7 Appendices	23
7.1 Appendix on calibration hierarchy	23
7.2 Typical heat flux ranges	23
7.3 Typical HF03 sensitivity	23
7.4 EU declaration of conformity	24

List of symbols

Quantities

	Symbol	Unit
Heat flux	Φ	W/m ²
Voltage output	U	V
Sensitivity	S	V/(W/m ²)
Temperature	T	°C
Resistance	R	Ω

Subscripts

N/A

Introduction

HF03 is a heat flux sensor commonly used in fire testing. It is designed for short (exposure time < 10 min) monitoring and measurement in high flux environments in the heat flux range up to $10 \times 10^3 \text{ W/m}^2$.

LI19 displays the measured heat flux. Once programmed with the sensitivity of the connected sensor, the display will show the actual value of the heat flux in W/m^2 . Programming LI19 is done through its PC user interface. LI19 communicates over USB. We recommend downloading the latest software. LI19 may also be used to store measured data. LI19 is battery powered, using 2 x AA-type batteries. Fresh batteries allow 50 days of operation. HF03-LI19 is not rated for EEx (potentially explosive) environments, nevertheless it is admitted in many cases, because the instrument operates on 3 VDC only.

Operation of HF03-LI19 is easy. As LI19 has already been programmed at the factory, measurements can start by switching on the LI19. The data storage interval is set by using the LI19 user interface software.

Hukseflux provides a traceable calibration. The reference standard at Hukseflux is of secondary standard level. It has been calibrated by comparison to the primary standard of the [RISE Research Institutes of Sweden AB](#) (formerly known as Statens Provningsanstalt (SP)). HF03 sensors as supplied by Hukseflux are calibrated according to ISO TS 14934-3. Hukseflux is ISO 9001 certified, but not an accredited measurement laboratory according to ISO 17025.



Figure 0.1 HF03, pictured without and with the included protection cap. Standard cable length is 5 m.



Figure 0.2 HF03-LI19 portable heat flux sensor with read-out unit



Figure 0.3 HF03-LI19 portable heat flux sensor with read-out unit in use for studying flares.

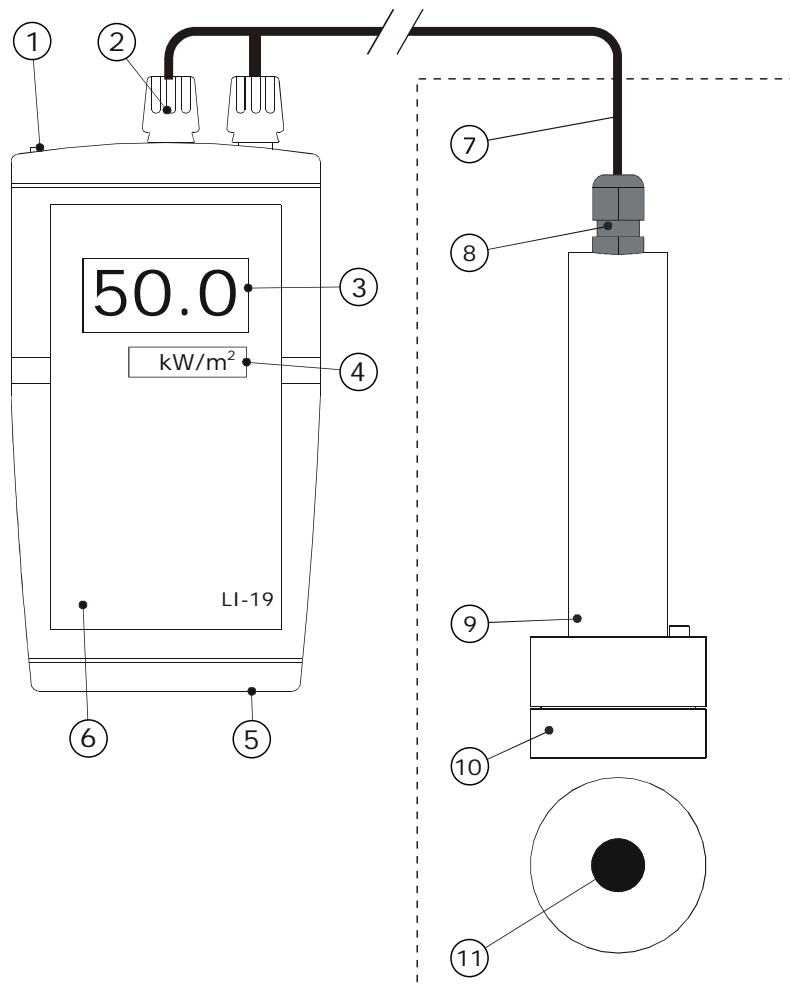

Figure 0.4 LI19 connected to HF03:

(1) on/off switch, (2) 2 x chassis plugs with screwed signal wire clamp, (3) display, (4) unit marker, (5) USB connector, (6) battery compartment, (7) HF03 cable, (8) cable gland, (9) plastic hand-grip, (10) metal heat sink, (11) thermopile sensor with black coating

1 Ordering and checking at delivery

1.1 Ordering HF03-LI19

HF03-LI19 is available in one standard version only.

1.2 Included items

Arriving at the customer, the delivery should include:

- HF03 with protection cap
- programmed LI19 with 2 x AA battery
- 2 spare batteries (type AA)
- transport case with space for sensors
- LI19 product certificate
- HF03 product certificate
- strip with measurement unit markers
- USB cable
- LI19 software

1.3 Latest software

The latest software should be downloaded from: www.hukseflux.com/page/downloads

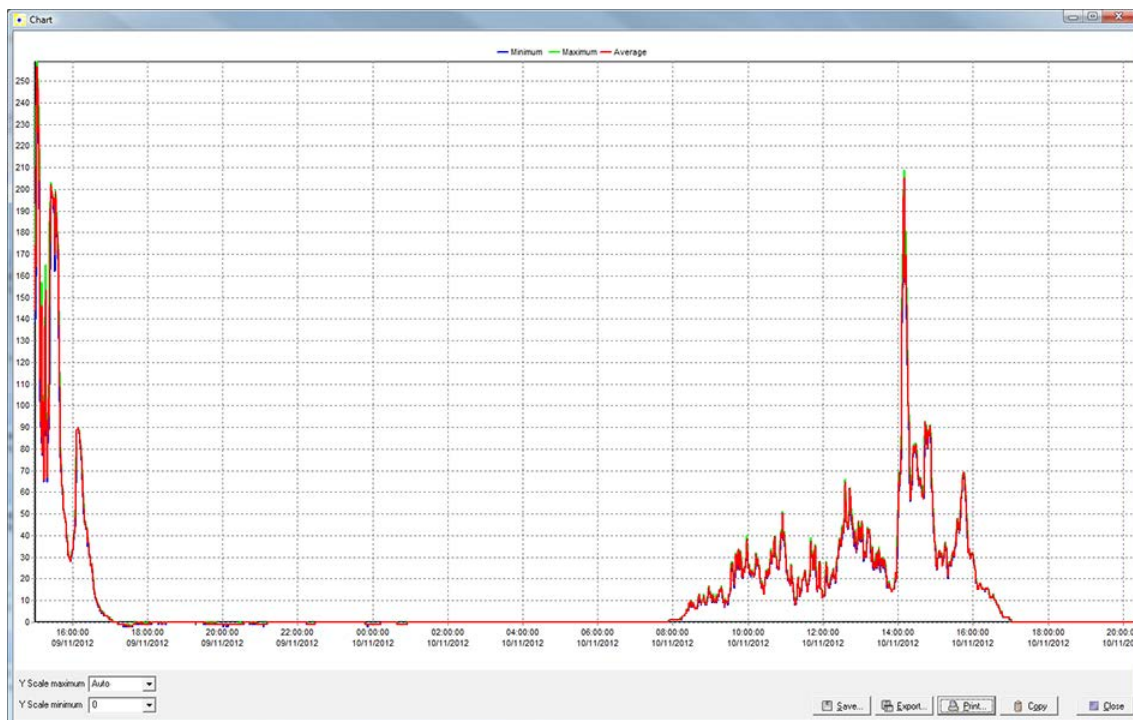

Figure 1.3.1 Screenshot of a plot created by the LI19 software user interface on PC

1.4 Quick instrument functionality check

- connect the LI19 to the HF03 sensor,
[white] wire to [red] plug, [green] wire to [black] plug
- switch on the LI19
- check sensor sensitivity settings on the display (displayed 1 s after start-up)
against the HF03 product certificate and on the handgrip
- check the zero signal with the protection cap on the HF03
- remove the protection cap from HF03
- check the functionality of the system by short exposure to a strong heat flux
source
- start measurement; write down measured values as seen on the screen

2 Instrument principle and theory

HF03 is a sensor that measures heat flux. It is mainly used to test reaction to fire and fire resistance. HF03 measures heat flux in the range of (0 to 10) x 10³ W/m². Equipped with a black absorber, heat flux sensors of this type are designed for measurement in an environment in which heat flux is dominated by radiation. Using an open detector, HF03 is also sensitive to convective heat flux. This contribution is usually ignored. Application in environments with significant heat transport to the sensor by convection is possible but requires a careful evaluation of the measurement uncertainty. HF03's thermopile sensor generates an output voltage proportional to the incoming irradiance.

The heat flux, Φ , in W/m², is calculated by dividing the HF03 output, a small voltage U , by the sensitivity S .

The measurement function of HF03 is:

$$\Phi = U/S \quad \text{(Formula 2.1)}$$

The sensitivity is provided with HF03 on its product certificate.

For readout the user only needs an accurate voltmeter that works in the millivolt range, such as the LI19. To convert the measured voltage, U , to a heat flux Φ , the voltage must be divided by the sensitivity S , a constant that is supplied with each individual sensor.

LI19 performs the measurement of the sensor output voltage, as well as the conversion to W/m². For the conversion the HF03 sensitivity must be entered into the LI19. It also stores data. The LI19 software serves as a user interface on PC.

3 Specifications of HF03-LI19

HF03-LI19 measures and displays the heat flux density through the surface of the HF03 sensor. This quantity, expressed in W/m^2 , is called heat flux. HF03 is rated for use in environments in which the heat flux is dominated by radiation at heat flux levels up to $10 \times 10^3 W/m^2$. It measures the combined radiative and convective heat flux.

The rated exposure interval of HF03 is 10 min. LI19 should not be exposed to the same heat flux source. LI19 is battery powered. Programming LI19 is done through its PC user interface. It communicates via USB.

Table 3.1 *Specifications of HF03-LI19 (continued on next pages)*

HF03 SPECIFICATIONS	
Sensor type	portable heat flux sensor
Measurand	heat flux
Measurand in SI units	irradiance in W/m^2
Full field of view angle	180 °
Rated measurement range	0 to $10 \times 10^3 W/m^2$
Limiting measurement range	150 % of rated measurement range
Output signal	DC voltage
Sensitivity range	0.1 to $0.7 \times 10^{-6} V/(W/m^2)$
Response time (63 %)	$< 450 \times 10^{-3} s$
Measurement function / required programming	$\Phi = U/S$
Rated operating temperature range	-30 to +80 °C (sensor body temperature)
Sensor resistance	25 Ω (nominal)
Required sensor power	zero (passive sensor)
Rated operating relative humidity range	0 to 100 % (non condensing)
Standard cable length	5 m
Cable material type	PUR
Cable diameter	$4 \times 10^{-3} m$
Wiring colour code	white [+], green [-]
IP protection class	IP10
Sensor marking	serial number and sensitivity are marked on hand grip
Rated exposure time interval	0 to 10 min
Weight of metal sensor body	0.33 kg
Metal heat capacity	400 J/(kg·K)
Heat capacity of sensor body	132 J/K

Table 3.1 Specifications of HF03-LI19 (started on previous pages, continued on the next page)

HF03 INSTALLATION AND USE	
Installation	HF03 is usually pointed at the main source of radiation
HF03 CALIBRATION	
Calibration traceability	to ITS-90
Standard governing calibration	ISO TS 14934-3: Reaction-to-Fire Tests - calibration of heat flux meters secondary calibration
Product certificate	included (showing calibration result and traceability)
Calibration method	SBGC secondary calibration method according to ISO 14934-3. The Hukseflux SBGC method follows the recommended practice of ISO 14934-3, however we calibrate HF03 at one heat flux level only: $10 \times 10^3 \text{ W/m}^2$. Calibration relies on a comparison to a secondary standard heat flux sensor under a radiant heat source. The calibration reference has been characterised at $10 \times 10^3 \text{ W/m}^2$.
Calibration laboratory accreditation	not accredited
Calibration laboratory management system certification	ISO 9001
Calibration hierarchy	from SI through international standards and through an internal mathematical procedure
Calibration uncertainty	$< 6.5 \% (k = 2)$
Recommended recalibration interval	1 yr
Calibration reference conditions	cooling water temperature $< 25 \text{ }^\circ\text{C}$, heat flux at $10 \times 10^3 \text{ W/m}^2 \pm 20 \%$
Validity of calibration	based on experience the instrument sensitivity will not change during storage.
MEASUREMENT ACCURACY	
Uncertainty of the measurement	statements about the overall measurement uncertainty can only be made on an individual basis. see the chapter on uncertainty evaluation.
ACCESSORIES	
Spare part	removable protection cap HF03

Table 3.1 Specifications of HF03-LI19 (started on previous pages)

LI19 SPECIFICATIONS	
Instrument type	read-out unit / datalogger
Measurand	analogue voltage with conversion to W/m ²
Output in display with HF03	heat flux in x 10 ³ W/m ²
Stored measurement definition	minimum, maximum and average over storage interval with conversion to W/m ²
Storage interval range	2 to 65535 s (selectable)
Display refreshment rate	1 s ⁻¹
Sample rate	2 s ⁻¹
Display resolution with HF03	0.1 x 10 ³ W/m ²
Storage capacity	3518 measurements
Rated operating temperature range	-10 to +40 °C
Temperature dependence	< 0.5 % + 3 x 10 ⁻⁶ V over rated range
Internal power supply voltage	3 VDC
Battery type	2 x AA
Battery life	> 50 days (on fresh batteries)
Rated exposure range	< 2 x 10 ³ W/m ²
Latest software version	see http://www.hukseflux.com/page/downloads
Connection to PC	via USB 1.1 / 2.0 low speed
User interface on PC	LI19 software
System requirements for use with PC	Windows XP and later, USB port
A/D conversion	16 bits
Wiring colour code	red [+], black [-]
Connection to sensor	2 x (female chassis plug for 4 mm banana plug, with screwed signal wire clamp)
Indicators on display	▲: data from PC to LI19 ▼: data to PC from LI19 BAT: battery low m: storing in memory l: sampling active
PACKAGING / TRANSPORT HF03-LI19	
Gross weight	2.5 kg HF03-LI19 + transport casing (black plastic) and packaging (carton box)
Net weight	1 kg HF03-LI19
Packaging	transport casing (black plastic) in carton box of (300 x 400 x 180) mm
Packaging	transport casing (black plastic) (300 x 400 x 120) mm

4 Installation of HF03-LI19

4.1 Electrical connection

Table 4.1.1 *The electrical connection of HF03 to LI19*

HF03 OUTPUT	WIRE	LI 19 PLUGS
signal [+]	White	Red
signal [-]	Green	Black
ground	Black	not connected



Figure 4.1.1 *Connectors and on/off switch on LI19. Connectors are 2 x female chassis plugs for 4 mm banana plug, with screwed signal wire clamps*

4.2 Software installation on the PC

The LI19 program is installed from the CD-ROM, or by downloading via internet. Installation of the LI19 program is done automatically by the Windows installer. In case older program versions are in use, these must be uninstalled. For the latest version of the LI19 software, see www.hukseflux.com/page/downloads.

5 Recommended practices for use

5.1 Short user guide

Table 5.1 *Recommended practices for use*

HF03-LI19 RECOMMENDED PRACTICES FOR USE		
1	Unpack HF03-LI19	check shipment contents (see paragraph on included items)
2	Double check	make sure fresh batteries are installed and added as spares. Look at the BAT indicator on screen
3	Download the latest software to the PC	see www.hukseflux.com/page/downloads
4	Put the unit marker into place	for use with HF03 the unit marker kW/m ² must be used.
5	Connect HF03 to LI19	see the paragraph on electrical connections: HF03 [white] to LI19 [red]. HF03 [green] to LI19 [black]
6	Switch on the LI19	use the push button switch on top. Check the sensitivity setting of LI19 against the HF03 sensitivity on the hand-grip. This sensitivity appears 1 s after switching on the LI19, and should be between 100 and 700
7	Look for indicators on the display	▲: data from PC to LI19 ▼: data to PC from LI19 BAT: battery low m: storing in memory l: measurement with data storage active
8	Optional: Connect LI19 to the PC, make contact to LI19 via the user interface	see the paragraph on the LI19 software
9	Optional: Check the LI19 settings via PC	check the sensitivity setting and the definition of stored measurements
10	Optional: Disconnect LI19 from the PC	
11	Remove the HF03 protection cap	inspect the heat flux sensor surface. The 10 x 10 ⁻³ m diameter sensing surface should be black
12	Perform measurements	do not expose HF03 for more than 10 min to strong radiation sources. Do not expose LI19 to strong radiation sources. write down measured data
13	Optional: backup data to PC	
14	Switch off LI19	
15	Store HF03-LI19 in its transport case in a dry environment	

5.2 Directions for measurement

HF03 and LI19 are suitable for outdoor use in a dry environment only. LI19's rated temperature range is from -10 to + 40 °C.

HF03 measures the heat flux through the plane of the black sensor. Make sure the orientation of the HF03 matches the orientation of the plane of interest.

For studies of exposure of personnel and equipment, the maximum or worst-case heat flux is usually found by measuring at the relevant location and by pointing the HF03 at the strongest local radiation source.

5.3 Battery replacement

Batteries must be replaced on a regular basis. To access the battery compartment, the bottom panel of LI19 can be removed manually. 2 x AA batteries are needed.



Figure 5.3.1 *Battery replacement of LI19*

5.4 The LI19 user interface on PC

When the LI19 program is activated, and the LI19 is switched on and connected, the program will automatically recognise the LI19 and a window as in the figure below will open, confirming that the LI19 is connected.

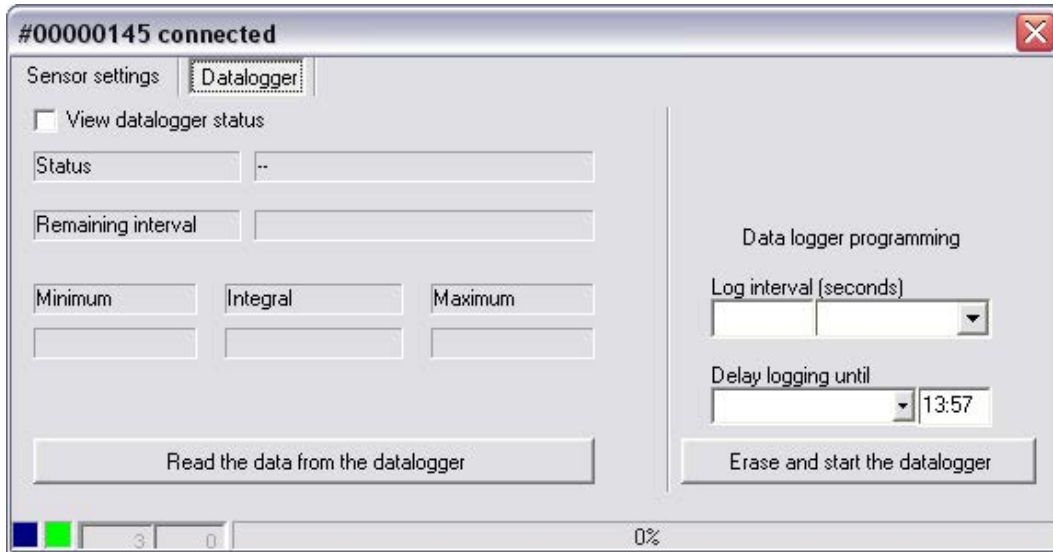

Figure 5.4.1 LI19 user interface, confirming that LI19 is connected

When selecting [sensor settings], and [select sensor] select [HF03]. Select the appropriate sensitivity for the HF03 from the calibration certificate or the hand-grip. This sensitivity will be between 0.1 and $0.7 \times 10^{-6} \text{ V}/(\text{W}/\text{m}^2)$ and is entered as a number between 100 to 700 in the LI19. The LI19 is now ready for use for display of the heat flux in $[\times 10^3 \text{ W}/\text{m}^2]$. We suggest to make a sticker on the LI19, stating the calibration which should appear on screen.

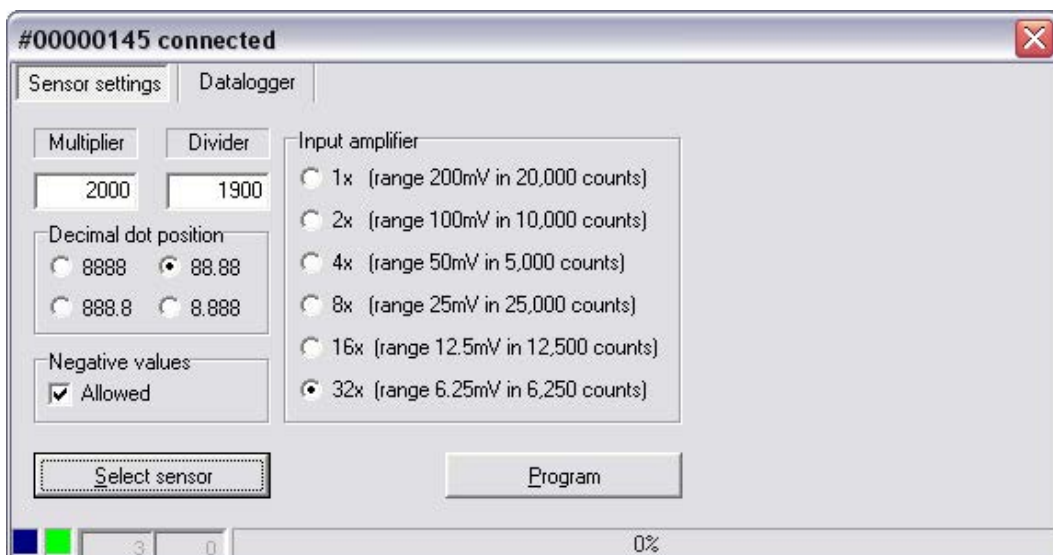

Figure 5.4.2 The [sensor settings] screen

5.4.1 Optional functionality of LI19

LI19 user interface on PC may perform several functions that are not necessarily used with HF03:

Setting the sensor sensitivity

Setting the data storage interval

Setting the initial delay time interval for data storage

Reading LI19 status (does not interfere with the logging process)

Reading measured data (presenting a chart)

Export stored data (from the LI19 to the PC)

6 Maintenance and trouble shooting

6.1 Recommended maintenance and quality assurance

HF03-LI19 is typically located in hostile environments in which the sensor is under constant threat of being damaged. Unreliable measurement results are detected by frequent recalibration, by visual inspection of the sensor and by scientific judgement, for example by looking for unreasonably large or small measured values.

Table 6.1.1 *Recommended maintenance of HF03-LI19*

MINIMUM RECOMMENDED HEAT FLUX SENSOR MAINTENANCE			
	INTERVAL	SUBJECT	ACTION
1	before and after every test	inspection	inspect sensor coating, cable quality
2	after every test	data review	judge the feasibility of the measurement data Compare to measurements with other sensors, typically heat flux and temperature measurements
3	after every test	lifetime assessment	judge if the instrument will be reliable for another test
4	every year	recalibration	recalibrate HF03 as well as LI19 at the manufacturer or a local calibration reference

6.2 Trouble shooting

Table 6.2.1 *Trouble shooting for HF03-LI19*

General	<p>Switch the LI19 on. Look at the sensor screen</p> <p>At start-up a figure between 100 and 700 should appear on screen. Check if this figure matches the HF03 sensitivity.</p> <p>[BAT] indicates a low battery. In that case, replace batteries.</p> <p>Inspect the sensor for any damage, in particular the black sensor surface.</p> <p>Inspect if the wires are properly attached to the LI19.</p> <p>Check the condition of the cable.</p> <p>Check the LI19 program in particular if the right sensitivity is entered.</p> <p>Check the electrical resistance of the sensor between the white [-] and green [+] wires. Use a multimeter at the 100 Ω range. Measure the sensor resistance first with one polarity, then reverse the polarity. Take the average value. Typical resistance should be the nominal sensor resistance of 25 Ω for plus 1.5 Ω for the total resistance of two wires (back and forth) of each 5 m. Infinite resistance indicates a broken circuit; zero or a lower than 1 Ω resistance indicates a short circuit.</p>
The sensor does not give any signal	<p>Remove the white cap from the sensor.</p> <p>Check if the sensor reacts to heat: use the LI19. Expose the sensor heat, for instance by putting a flame from a consumer type gas lighter at a distance of around 0.01 m. The signal should read $> 1 \times 10^3 \text{ W/m}^2$ now. Do not expose for more than 10 s.</p> <p>Check the data acquisition by replacing the sensor with a spare unit.</p>
The sensor signal is unrealistically high or low	<p>Check the cable condition looking for cable breaks.</p> <p>Check the LI19 by applying a $1 \times 10^{-3} \text{ V}$ source to it. Look at the measurement result. Check if it is as expected.</p> <p>Check the LI19 by short circuiting the data acquisition input with a 10 Ω resistor. Look at the output. Check if the output is close to 0 W/m^2.</p>
The sensor signal shows unexpected variations	<p>Check the presence of strong sources of electromagnetic radiation (radar, radio).</p>

6.3 Recoating / repainting of sensor surfaces

ISO 14934-4 paragraph 9.1 allows repainting of sensors, according to manufacturer recommendations. Hukseflux recommendations are:

Repainting is preferably done by the manufacturer. Do-it-yourself repainting is possible but if that is done all product warranties are cancelled.

Judge by visual inspection if the thermopile sensor is still well attached to the metal sensor body. If not, the sensor is beyond repair. Verify sensor functionality. This can also be done with a non-coated sensor (see the chapter of the quick sensor test). The thermopile is then visible through its orange coloured plastic cover.

Purchase a matt (not glossy) black paint which is temperature resistant up to 600 $^{\circ}\text{C}$. Silicone based black paints are a good choice. Typically aerosol spray cans are most easy to use, but such paints can also be used purchased in cans. In case a solvent is needed: typically acetone is a good solvent for these paints.

Surface preparation: In case the existing sensor surface coating has small scratches but is otherwise in good condition, do not clean, but apply new paint directly to the existing paint. In case of heavy damage to sensor surface coatings: remove the existing coating, clean with acetone or ethanol. Lightly sand the orange plastic surface. Take care to leave the thermopile plastic cover intact.

Paint application: the sensor surface is located in a 0.1×10^{-3} m deep locally lower surface in the SBG01 body. Spray some paint in a small cup, use a pipette to apply the paint. In case a pipette is not available, use a small paint brush.

Recalibration: newly coated sensors should be recalibrated. We do not expect significant (> 5 %) changes relative to the original sensitivity.

7 Appendices

7.1 Appendix on calibration hierarchy

HF03 factory calibration is traceable from SI through international standards and through an internal mathematical procedure. The formal traceability of the generated heat flux is through a secondary standard calibration reference to the international temperature standard ITS90. The Hukseflux SBGC method follows the recommended practice of ISO 14934-3, however we calibrate at one heat flux level only. Calibration relies on a comparison to a secondary standard heat flux sensor under a radiant heat source. HF03 is calibrated at a heat flux level of $10 \times 10^3 \text{ W/m}^2$.

7.2 Typical heat flux ranges

Table 7.2.1 Allowable heat flux levels in industrial environments

		$\times 10^3 \text{ W/m}^2$	Btu/hr Ft ²
1	Equipment	9.5	3000
2	Human: Run	6.3	2000
3	Human: Walk	4.7	1500
4	Human: Work (static)	1.6	500

Table 7.2.2 Typical ranges of heat flux levels, from ISO 14934-4

	$\times 10^3 \text{ W/m}^2$	Comment
1	300	maximum level in a fully developed fire
2	200 to 100	incident heat flux on the wall in a developed fire enclosure
3	about 100	radiation from burning house
4	about 30	causing ignition of tree
5	20 to 10	causing ignition of timber
6	about 7 or 8	lowest level for causing ignition of a timber wall under a pilot flame
7	about 4	lowest level for causing a burn
8	about 2,5	highest level for people to endure
9	1,5	solar constant, maximum level of solar irradiance

7.3 Typical HF03 sensitivity

Table 7.3.1 typical sensitivity of HF03, 2015 production figures, not to be used as reference. NOTE: in the LI19 the sensitivity is entered as a number between 100 and 700

	MODEL	SENSITIVITY $\times 10^{-6} \text{ V/(W/m}^2)$
1	HF03	0.25 to 0.65

7.4 EU declaration of conformity



We, Hukseflux Thermal Sensors B.V.
Delftechpark 31
2628 XJ Delft
The Netherlands

in accordance with the requirements of the following directive:

2014/30/EU The Electromagnetic Compatibility Directive

hereby declare under our sole responsibility that:

Product model: HF03-LI19
Product type: Portable heat flux sensor with read-out unit / datalogger

has been designed to comply and is in conformity with the relevant sections and applicable requirements of the following standards:

Emission: EN 61326-1: 2013
Immunity: EN 61326-1: 2013

A handwritten signature in blue ink, appearing to be 'Eric Hoeksema', written over a faint circular stamp or watermark.

Eric HOEKSEMA
Director
Delft
March 01, 2016

