

USER MANUAL **PMF SERIES**

A full range of pyranometer mounting fixtures

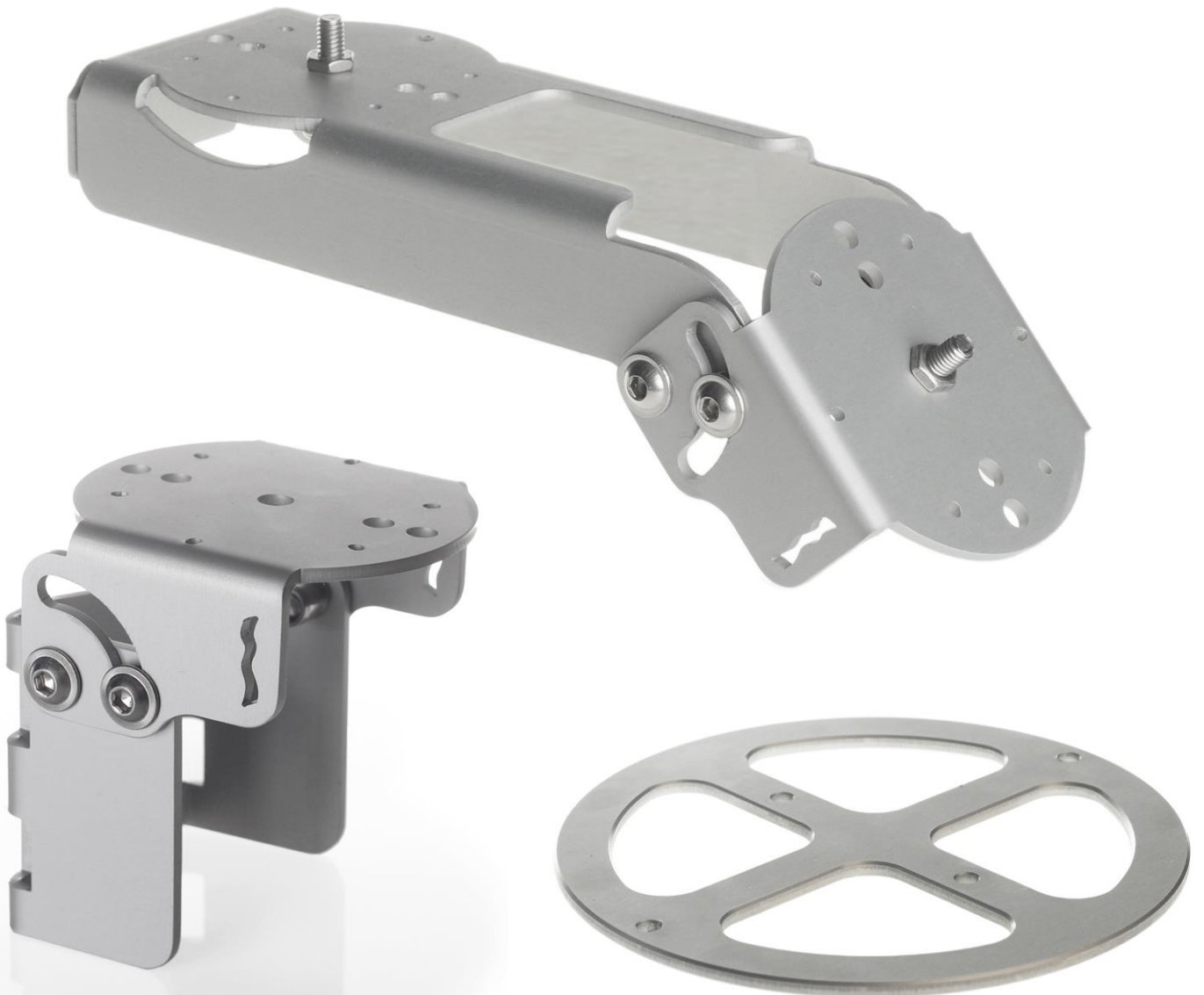

Contents

Contents	2
Warning statements	3
Introduction	4
PMF01	4
PMF02	4
VMA01 option for PMF01	4
1 Ordering and checking at delivery	9
1.1 Ordering PMF series pyranometer mounting fixtures	9
1.2 Included items	9
2 Specifications of PMF series	11
2.1 Specifications of PMF01 pyranometer mounting fixture	11
2.2 Specifications of PMF02 dual pyranometer mounting fixture	12
2.3 Specifications of VMA01 ventilation mounting adapter	13
2.4 Dimensions of PMF series	14
3 Installation of PMF01	16
3.1 Site selection and installation	16
3.2 Installation options	16
3.3 Crossarm mounting installations	16
3.4 Mast mounting installations	20
3.5 Platform- or surface mounting installations	24
3.6 Tilted, Plane of Array (POA) mounting installations	26
4 Installation of PMF02	28
4.1 Site selection and installation	28
4.2 GHI and tilted, Plane of Array (POA) mounting installations	28
5 Installation of VMA01	30
5.1 Site selection and installation	30
5.2 GHI or tilted, Plane of Array (POA) mounting installations	30
6 Appendices	33
6.1 Appendix on tools for PMF series	33
6.2 Appendix on spare parts for PMF series	33

Warning statements



When using PMF01's tube clamp, tightening of the tube clamp should not exceed 6 Nm.



Do not mount pyranometers or their brackets directly to a PV panel or array mounting frame. Consider the electrical grounding of the instruments.

Introduction

Hukseflux offers an accessory range of practical brackets for mounting pyranometers. PMF01 is a metal bracket that helps mounting a pyranometer on a vertical mast, horizontal crossarm, flat wall or a fence. It allows for horizontal as well as tilted (Plane of Array) orientation, in all climates and weather conditions. With its small footprint, in particular when combined with small footprint pyranometers such as SR30 and SR15, PMF01 reduces snow build-up; snow will simply drop off. Model PMF02 enables a setup of two pyranometers, one horizontal, the other in POA; ideal for PV monitoring. PMF01 and PMF02 are compatible with all Hukseflux pyranometers. With the mounting adapter VMA01, VU01 ventilated pyranometers can also be installed on PMF01.

PMF01

PMF01 is a practical metal bracket that helps mounting a pyranometer on a vertical mast, horizontal crossarm, flat wall or a fence. It allows for horizontal as well as tilted (Plane of Array, or POA) orientation. The use of PMF01, compatible with all Hukseflux pyranometers, is easy. Its spring-loaded central bolt allows easy mounting and levelling of pyranometers. With its small footprint, in particular when combined with small footprint pyranometers such as SR30, PMF01 reduces problems with snow build-up; snow will simply drop off.

PMF02

PMF02 enables a setup of two pyranometers, of which one in POA, mounted to a surface or fence; ideal for PV system performance monitoring according to the latest IEC standards.

VMA01 option for PMF01

VMA01 is a ventilation mounting adapter allowing installation of the small footprint VU01 ventilation unit with a suitable Hukseflux pyranometer on PMF01.



Figure 0.1 PMF01 pyranometer mounting fixture – practical, small footprint – for all Hukseflux pyranometer models, for 1 x pyranometer, horizontal or tilted

Suggested use for PMF series pyranometer mounting fixtures:

- meteorological observations
- PV monitoring

Using PMF series pyranometer mounting fixtures offers several advantages:

- quick installation
- easy levelling using spring-loaded bolt
- for mounting pyranometers on horizontal and vertical tubes, on platforms, both horizontal and in Plane of Array

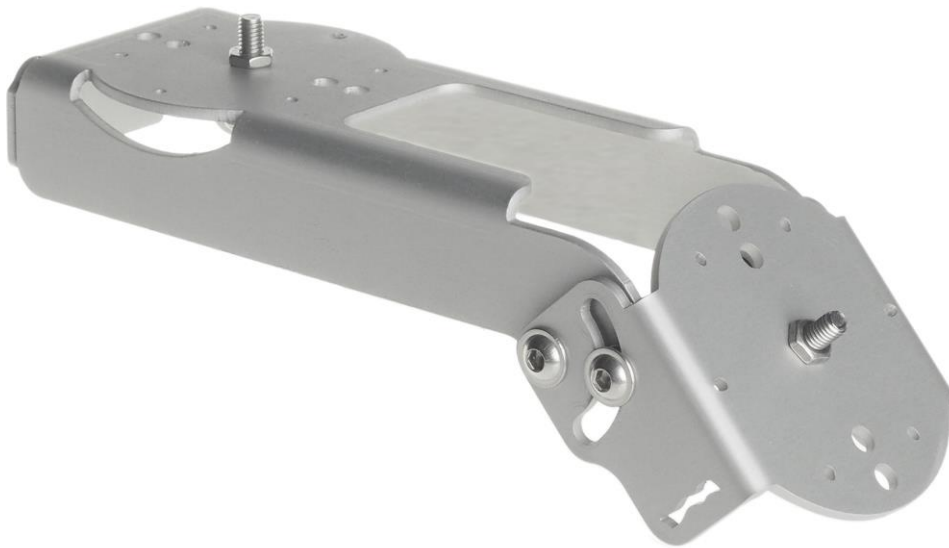

Figure 0.2 *PMF02 dual pyranometer mounting fixture – practical, small footprint – for all Hukseflux pyranometer models, for 1 x horizontal and 1 x tilted pyranometer*



Figure 0.3 *VMA01 ventilation mounting adapter for PMF01, for 1 x VU01 ventilated pyranometer, horizontal or tilted*

PMF series is a range of robust and versatile pyranometer mounting fixtures, made of anodised aluminium. PMF01's small footprint and 0 to 90 ° tilt angle ensure quick installation, horizontal or in Plane of Array, on either a vertical mast, horizontal crossarm or on a platform, in any climate and weather. Its spring-loaded bolt allows easy mounting and levelling of all Hukseflux pyranometers. With the addition of VMA01, a VU01 ventilation unit can also be mounted on PMF01. PMF02 is uniquely designed for PV system performance monitoring installations of two pyranometers, one in POA.

PMF01 and PMF02 pyranometer mounting fixtures fit all Hukseflux pyranometers, including:

- SR30, SR25, SR22, SR20, SR15, SR12, SR11, SR05, SR03 and LP02 pyranometer, and SR05's ball levelling mount.

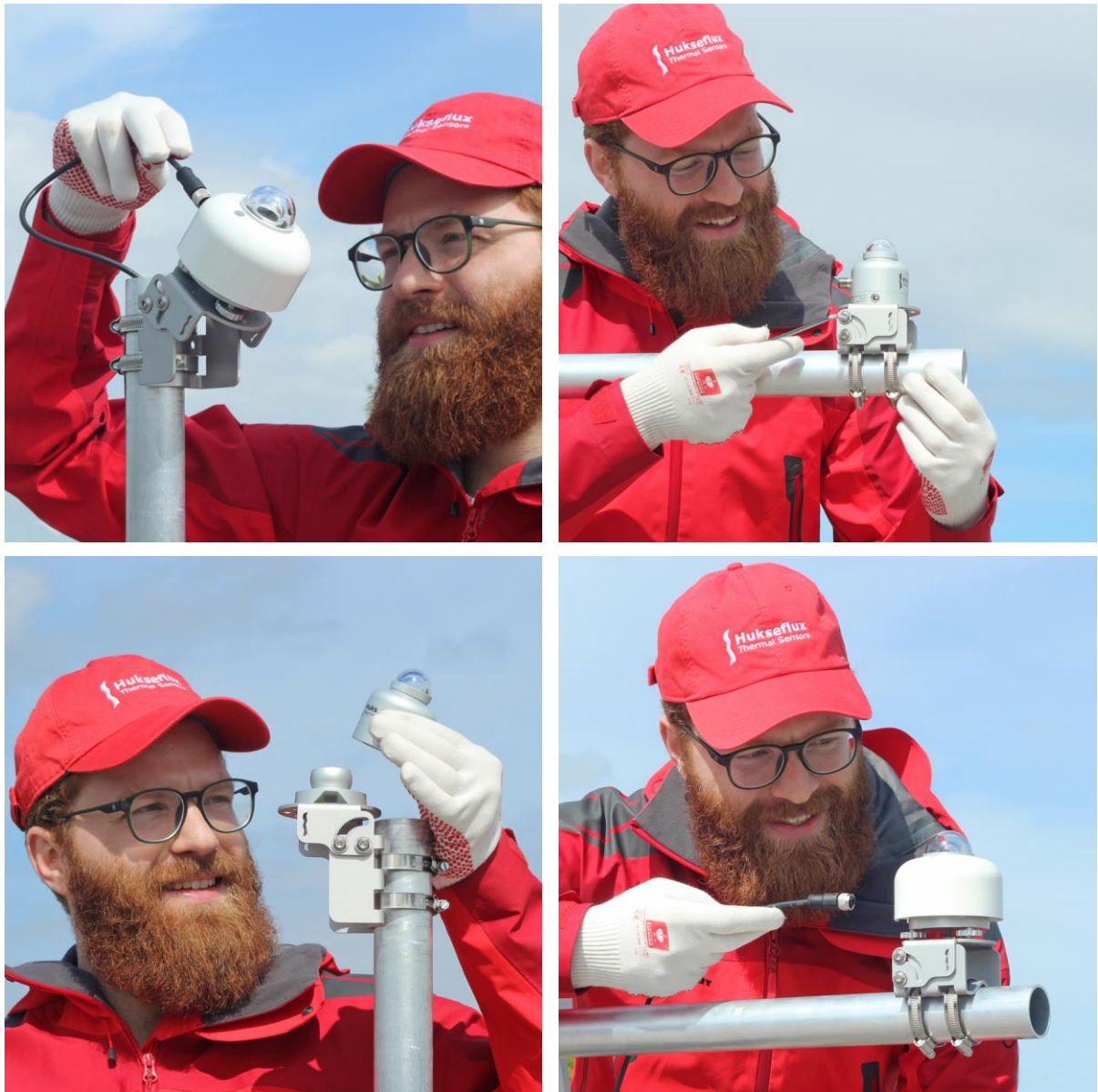

Figure 0.4 Hukseflux pyranometers with PMF01 pyranometer mounting fixtures on a horizontal crossarm and on a vertical mast, being installed both in Plane of Array (tilted) and horizontally. The versatile PMF01 allows for mounting on a surface, using bolts, as well

With the addition of VMA01 mounting adapter, VU01 ventilated pyranometers can also be mounted on a PMF01 pyranometer mounting fixture.



Figure 0.5 VMA01 is a mounting adapter allowing installations on PMF01 of the small footprint VU01 ventilation unit with a suitable Hukseflux pyranometer, horizontally or tilted



Figure 0.6 PMF02 is uniquely designed for PV system performance monitoring with two pyranometers, one in Plane of Array

Please also refer to your pyranometer user manual for a proper installation of that particular pyranometer with PMF series pyranometer mounting fixtures. The instrument should be used in accordance with the recommended practices of ISO, IEC, WMO and ASTM.

There are other mounting options available for SR30, SR15 and SR05. They allow for simplified mounting, levelling and instrument exchange on a flat surface or a tube.



Figure 0.7 Alternative mounting options are offered for SR30, SR15 and SR05 sensors

See also:

- [SR30](#) and [SR15](#) pyranometers with spring-loaded and tube levelling mount
- [SR05](#) with ball levelling and tube mount
- [VU01](#) ventilation unit
- view our complete [range of solar sensors](#)

1 Ordering and checking at delivery

1.1 Ordering PMF series pyranometer mounting fixtures

PMF series pyranometer mounting fixtures is a range of accessories for use with Hukseflux pyranometers.

The ordering codes of the different versions in the series are PMF01, PMF02 and VMA01.

Table 1 *Overview of versions in PMF series*

VERSIONS OF PMF SERIES	
PMF01	pyranometer mounting fixture, for all Hukseflux pyranometer models, for 1 x pyranometer, horizontal or tilted
PMF02	dual pyranometer mounting fixture, for all Hukseflux pyranometer models, for 1 x horizontal and 1 x tilted pyranometer
VMA01	ventilation mounting adapter for PMF01, for 1 x VU01 ventilated pyranometer, horizontal or tilted

When you wish to install a suitable pyranometer with VU01 ventilation unit on PMF01 pyranometer mounting fixture, please purchase both PMF01 and VMA01 mounting fixtures.

1.2 Included items

Arriving at the customer, the delivery should include:

- PMF01 pyranometer mounting fixture including:
 - bracket
 - 2 x tube clamp
 - 1 x spring
 - 1 x M6 nut
 - 1 x M6x25 bolt
 - 2 x M5x20 bolt
 - 2 x M5x10 bolt
 - 2 x M5 nut
- PMF02 dual pyranometer mounting fixture including:
 - bracket
 - 2 x spring
 - 2 x M6 nut
 - 2 x M6x25 bolt
 - 4 x M5x20 bolt
 - 4 x M5x10 bolt
 - 4 x M5 nut

- VMA01 ventilation mounting adapter for PMF01:
 - bracket
 - 2 x M5 bolt
 - 2 x M5 nut

2 Specifications of PMF series

2.1 Specifications of PMF01 pyranometer mounting fixture

PMF01 is a practical metal bracket that helps mounting a pyranometer on a vertical mast, horizontal crossarm, flat wall or a fence. It allows for horizontal as well as tilted (Plane of Array) orientation. The use of PMF01, compatible with all Hukseflux pyranometers, is easy. Its spring-loaded central bolt allows easy mounting and levelling.

PMF01 can only be used in combination with a suitable pyranometer.

Please also refer to your pyranometer user manual for a proper installation of that particular pyranometer with PMF01 pyranometer mounting fixture. The instrument should be used in accordance with the recommended practices of ISO, IEC, WMO and ASTM.

Table 2.1.1 *Specifications of PMF01*

PMF01 GENERAL SPECIFICATIONS	
Product type	bracket
Instrument compatibility	SR30, SR25, SR22, SR20, SR15, SR12, SR11, SR05, SR03 or LP02 pyranometer; compatible with SR05 ball levelling; compatible with VU01 ventilation unit if PMF01 is combined with VMA01 ventilation mounting adapter
Instrument compatibility	IR02 or IR20 (WS) pyrgeometer
Tube compatibility	diameter (27 to 60) x 10 ⁻³ m
Tilt angles	0 to 90 °
Material	anodised aluminium (tube clamps and bolts made of stainless steel)
Rated operating temperature	-40 to +80 °C
Included parts	bracket 2 x tube clamp 1 x spring 1 x M6 nut 1 x M6x25 bolt 2 x M5x10 bolt 2 x M5 nut
PMF01 MOUNTING	
To pyranometer:	
-central spring-loaded bolt,	1 x M6x25 bolt with spring and nut
-or with 2 bolts	either 2 x M5x20 or 2 x M5x10 bolts
To crossarm, mast or other tube:	
-2 tube clamps	for tube diameters (27 to 60) x 10 ⁻³ m
To platform allowing the use of bolts:	M6 (or smaller) bolts (not included)
Required tools (not included)	7 mm socket wrench 4 mm hex key
PMF01 TRANSPORT	
Gross weight	0.27 kg
Net weight	0.25 kg
Packaging	bubble wrap pouch of (100 x 90 x 55) mm

2.2 Specifications of PMF02 dual pyranometer mounting fixture

PMF02 is a practical metal bracket uniquely designed for PV system performance monitoring installations of two pyranometers, one in Plane of Array. The use of PMF02, compatible with all Hukseflux pyranometers, is easy. Its spring-loaded central bolts allow easy mounting and levelling of pyranometers.

PMF02 is made to be used in combination with two suitable pyranometers.

Please also refer to your pyranometer user manual for a proper installation of those particular pyranometers with PMF02 pyranometer mounting fixture. The instruments should be used in accordance with the recommended practices of ISO, IEC, WMO and ASTM.

Table 2.2.1 *Specifications of PMF02*

PMF02 GENERAL SPECIFICATIONS	
Product type	bracket
Instrument compatibility	2 x SR30, SR25, SR22, SR20, SR15, SR12, SR11, SR05, SR03 and LP02 pyranometers; compatible with SR05 ball levelling; not compatible with VU01 ventilation unit
Tilt angles	pyranometer 1 (GHI): 0 ° pyranometer 2 (POA): 0 to 90 °
Material	anodised aluminium (tube clamps and bolts made of stainless steel)
Rated operating temperature	-40 to +80 °C
Included parts	bracket 2 x M6 central spring-loaded bolt 2 x M6 nut 4 x M5 x 20 bolt 4 x M5 x 10 bolt 4 x M5 nut
PMF02 MOUNTING	
To fence / frame allowing the use of bolts:	M6 (or smaller) bolts (not included)
To pyranometer:	
-central spring-loaded bolt,	1 x M6x25 bolt with spring and nut
-or with 2 bolts	either 2 x M5x20 or 2 x M5x10 bolts
Required tools (not included)	7 mm socket wrench 4 mm hex key
PMF02 TRANSPORT	
Gross weight	0.28 kg
Net weight	0.26 kg
Packaging	bubble wrap pouch of (250 x 100 x 50) mm

2.3 Specifications of VMA01 ventilation mounting adapter

VMA01 is a practical mounting adapter that, when combined with PMF01, helps mounting VU01 externally ventilated pyranometers on a vertical mast, horizontal crossarm, flat wall or a fence. It allows for horizontal as well as tilted (Plane of Array) orientation. The use of VMA01, compatible with a Hukseflux pyranometer ventilated by VU01 ventilation unit, is easy.

VMA01 can only be used in combination with PMF01 and a VU01 ventilated pyranometer.

Please also refer to your pyranometer and ventilation unit user manual for a proper installation of that particular ventilated pyranometer with VMA01 mounting adapter. The instrument should be used in accordance with the recommended practices of ISO, IEC, WMO and ASTM.

Table 2.3.1 *Specifications of VMA01*

VMA01 GENERAL SPECIFICATIONS	
Product type	adapter plate
Instrument compatibility	VU01 ventilation unit with a suitable pyranometer (SR20, SR20-D2, SR22, SR25), combined with PMF01 pyranometer mounting fixture
Tilt angles	0 to 90 ° (when combined with PMF01)
Material	anodised aluminium (bolts made of stainless steel)
Rated operating temperature	-40 to +80 °C
Included parts	mounting adapter plate 2 x M5 bolts + 2 x M5 nuts
Other parts needed	2 x M5 bolts + 2 x M5 nuts (included with VU01)
VMA01 MOUNTING	
To PMF01	with 2 bolts (2 x M5 bolts)
To VU01	with 2 bolts (2 x M5 bolts, included with VU01)
Required tools (not included)	4 mm hex key
Installation with downfacing pyranometer	in case of mounting VU01 upside down, make sure to cover the VMA01 plate, in order to prevent snow or rain to enter VU01's filter
VMA01 TRANSPORT	
Gross weight	0.12 kg
Net weight	0.11 kg
Packaging	bubble wrap pouch of (160 x 160 x 20) mm

2.4 Dimensions of PMF series

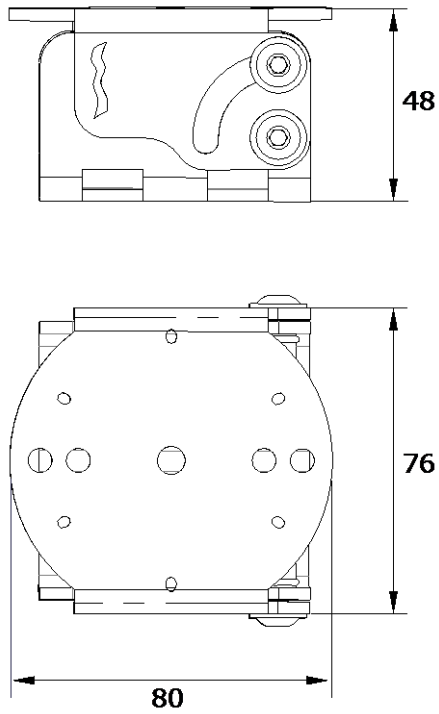

Figure 2.4.1 Dimensions of PMF01 in 10^{-3} m.

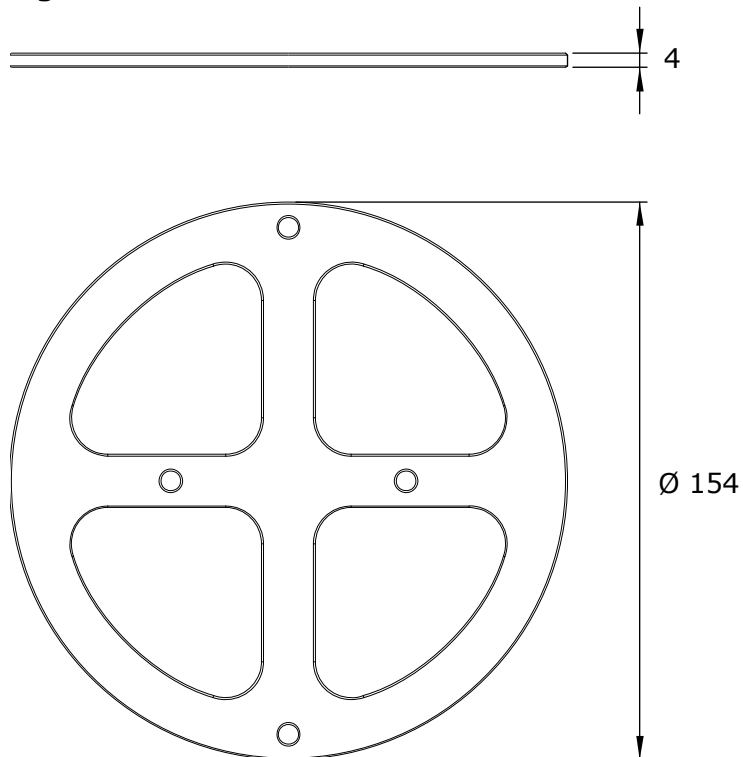

Figure 2.4.2 Dimensions of VMA01 in 10^{-3} m.

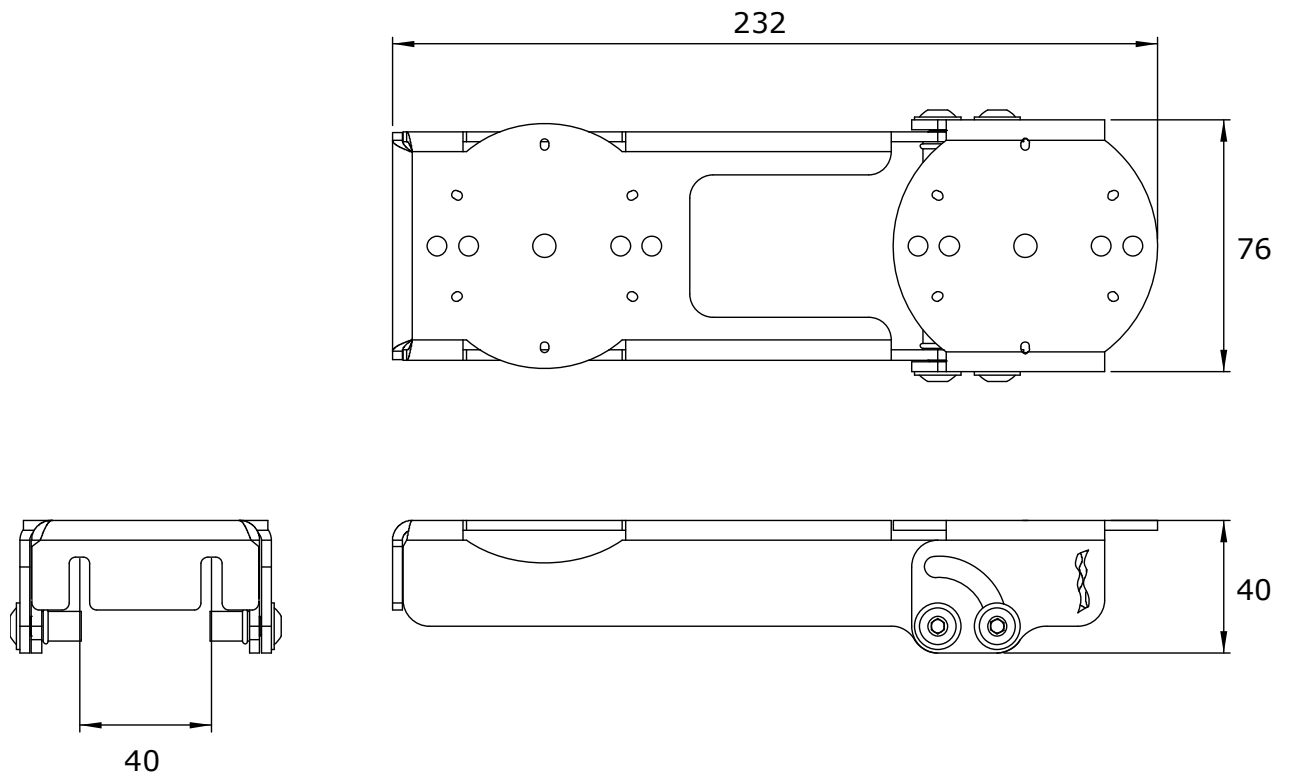

Figure 2.4.3 Dimensions of PMF02 in 10^{-3} m.

3 Installation of PMF01

3.1 Site selection and installation

Please also refer to your pyranometer user manual for a proper installation of that particular pyranometer with PMF01 pyranometer mounting fixture. The instrument should be used in accordance with the recommended practices of ISO, IEC, WMO and ASTM.

3.2 Installation options

PMF01 can be installed on a:

- horizontal crossarm
- vertical mast
- platform or surface, allowing the use of bolts

It allows for horizontal as well as tilted (Plane of Array) orientation.

Please see the following chapters for such an installation:

- Chapter 3.3 crossarm mounting installations
- Chapter 3.4 mast mounting installations
- Chapter 3.5 platform- or surface mounting installations
- Chapter 3.6 tilted, Plane of Array (POA) installations on any of the above

3.3 Crossarm mounting installations

When using PMF01 with a crossarm, or a similar horizontal tube or rod, please follow the instructions below:

1. Put the two tube clamps through the designated holes of PMF01 and mount the bracket onto the the crossarm by (loosely) tightening the clamps.

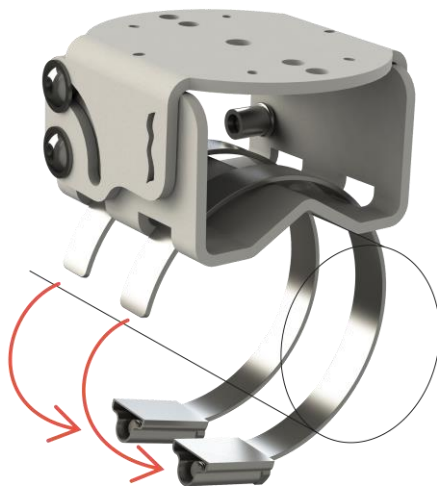

Figure 3.3.1 Installation of PMF01 on a horizontal crossarm, step 1

2. Open de top part of the bracket, tighten the bolts and install the sensor, either following step 3a or step 3b.

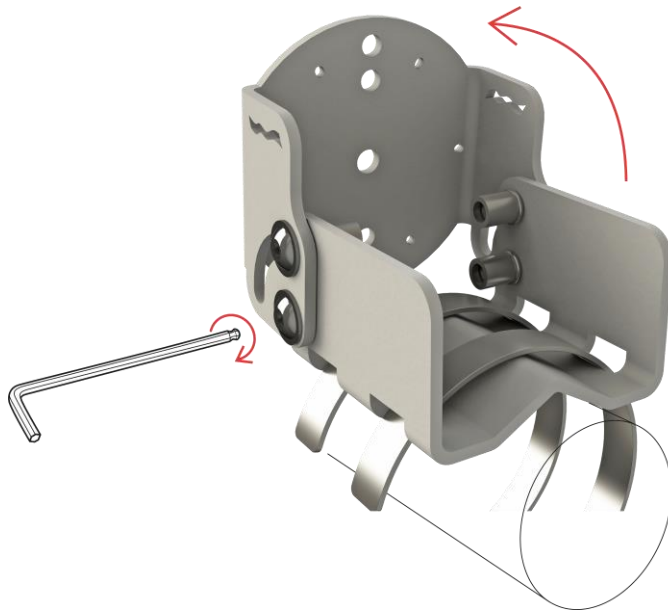

Figure 3.3.2 *Installation of PMF01 on a horizontal crossarm, step 2*

- 3a. Install the sensor using the spring-loaded bolt: Attach the M6x25 bolt with the spring to the bracket and lock it using the M6 nut. Put the sensor onto the bolt, place the sensor feet in the designated holes. Turn the bolt further into the sensor bottom plate by using a 4 mm hex key.

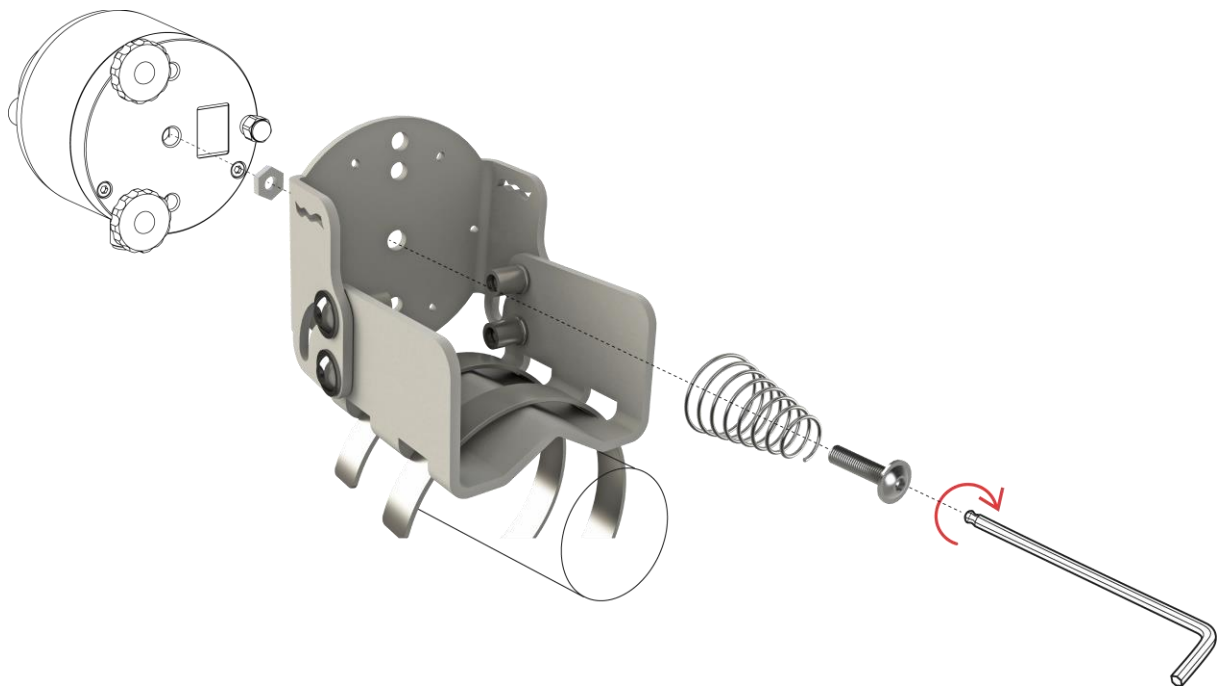

Figure 3.3.3 *Installation of PMF01 on a horizontal crossarm, step 3a*

3b. When not following step 3a, follow step 3b instead, using two M5 bolts. Place the sensor feet in the designated holes. Turn the bolts into the sensor through the bracket holes matching those of your pyranometer, and tighten the bolts using a 4 mm hex key.

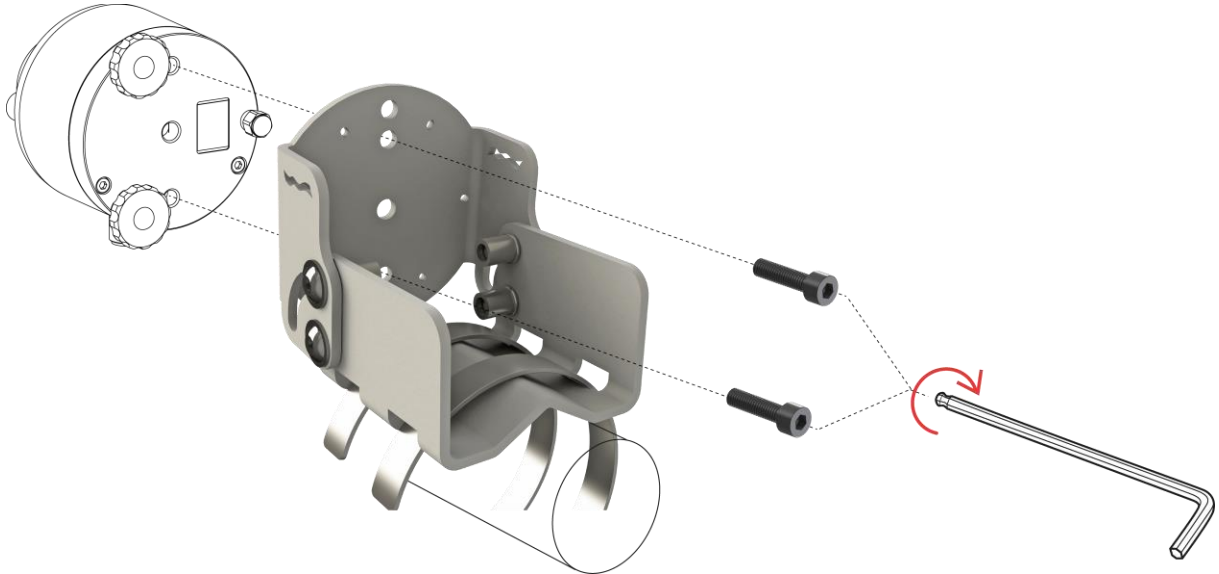

Figure 3.3.4 *Installation of PMF01 on a horizontal crossarm, step 3b*

4. Close the top part of PMF01. Level the sensor and (further) tighten the tube clamps and bolts.

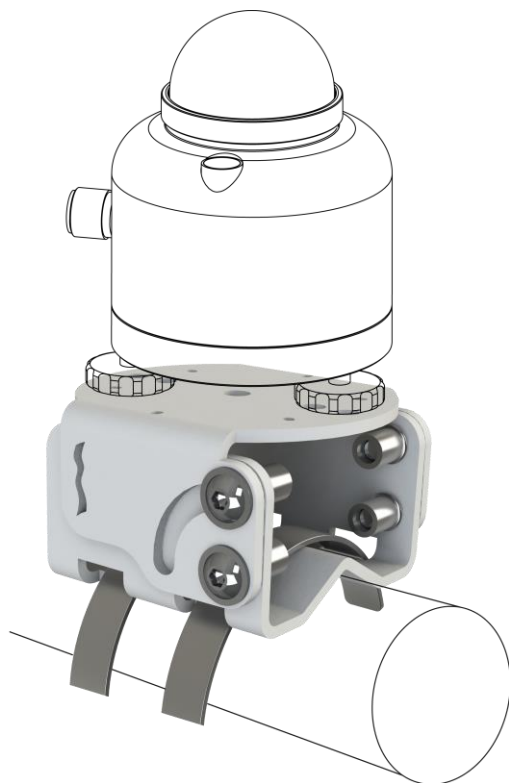

Figure 3.3.5 *Installation of PMF01 on a horizontal crossarm, step 4*

5. Finetune levelling the sensor using the levelling feet. See the pyranometer user manual for further instructions, for example on installations of screen caps and cabling.

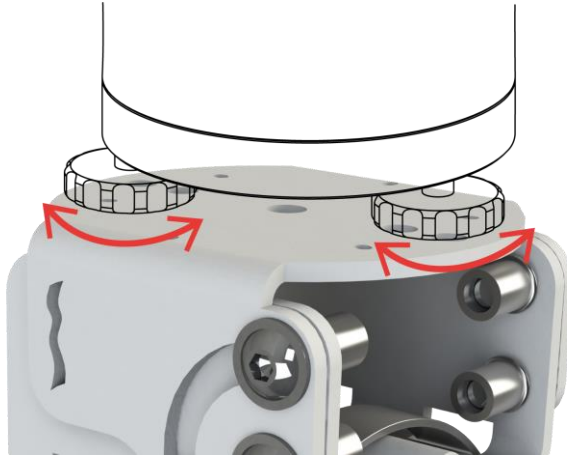

Figure 3.3.6 *Installation of PMF01 on a horizontal crossarm, step 5*

3.4 Mast mounting installations

When using PMF01 with a mast, or a similar vertical tube, rod or pole, please follow the instructions below.

1. Put the tube clamps through the designated PMF01 holes and mount the bracket onto the mast by tightening the tube clamps.

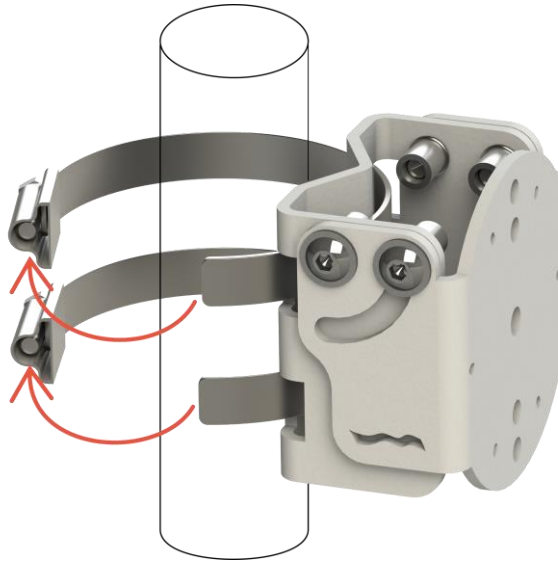

Figure 3.4.1 Installation of PMF01 on a vertical mast, step 1

2. Open the bracket, tighten the bolts and install the sensor, using either step 3a or step 3b

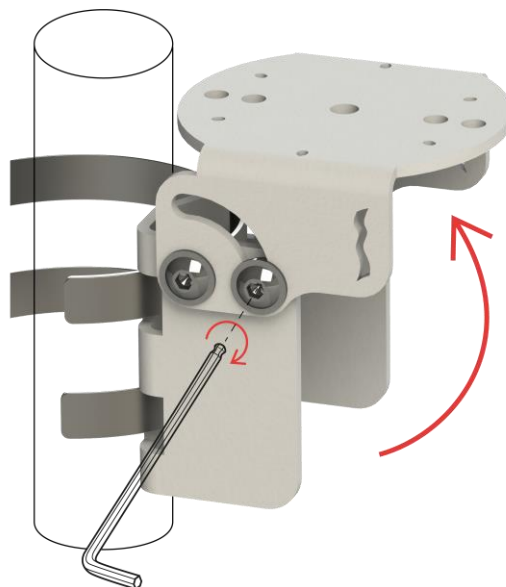

Figure 3.4.2 Installation of PMF01 on a vertical mast, step 2

- 3a. Install the sensor using the spring-loaded bolt: attach the M6x25 bolt with the spring to the bracket and lock it using the M6 nut. Put the sensor onto the bolt, place the sensor feet in the designated holes. Turn the bolt further into the sensor bottom plate by using a 4 mm hex key.

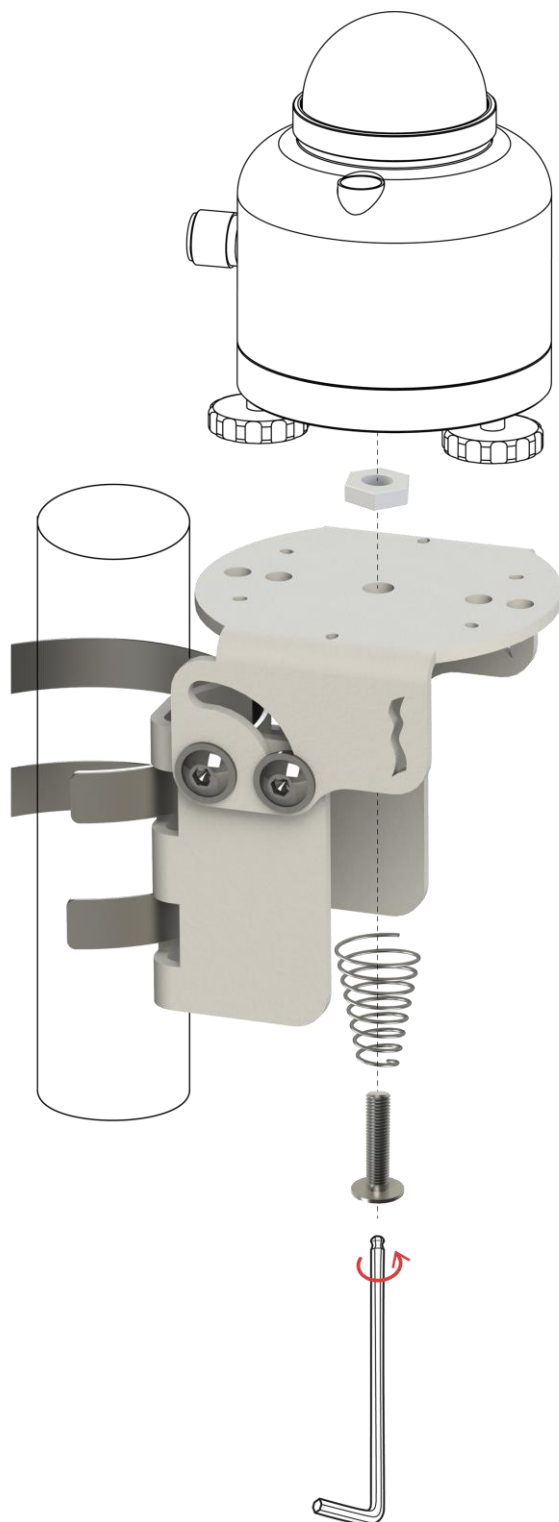

Figure 3.4.3 *Installation of PMF01 on a vertical mast, step 3a*

- 3b. When not following step 3a, follow step 3b instead, using two M5 bolts: Place the sensor feet in the designated holes. Turn the bolts into the sensor through the bracket holes matching those of your pyranometer, and tighten the bolts using a 4 mm hex key.

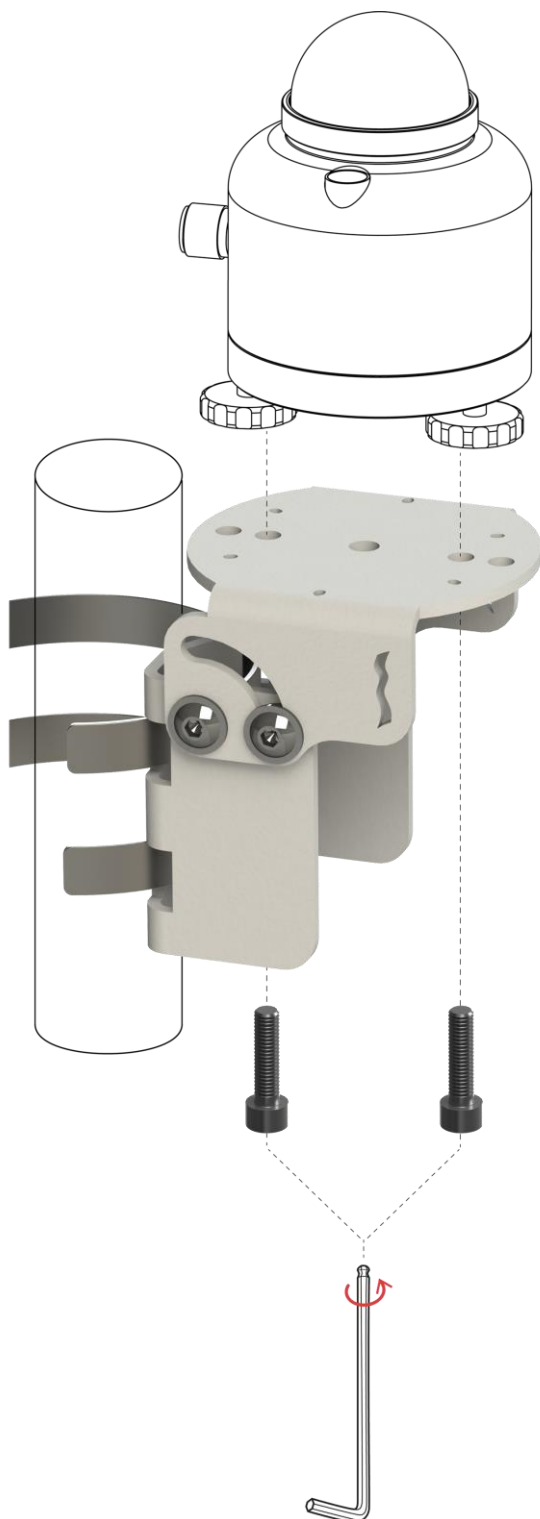

Figure 3.4.4 *Installation of PMF01 on a vertical mast, step 3b*

4. Tighten the tube clamps and the bolts once more.

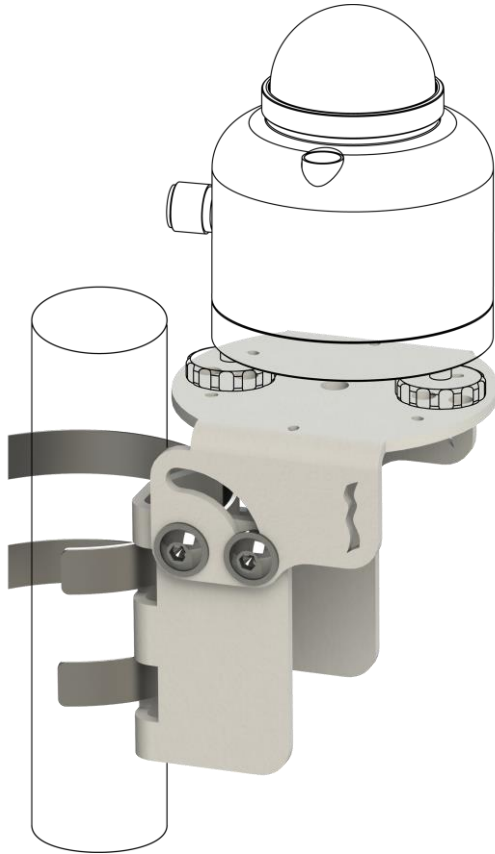

Figure 3.4.5 *Installation of PMF01 on a vertical mast, step 4*

5. Level the sensor using the levelling feet. See the pyranometer user manual for further instructions, for example on installations of screen caps and cabling.

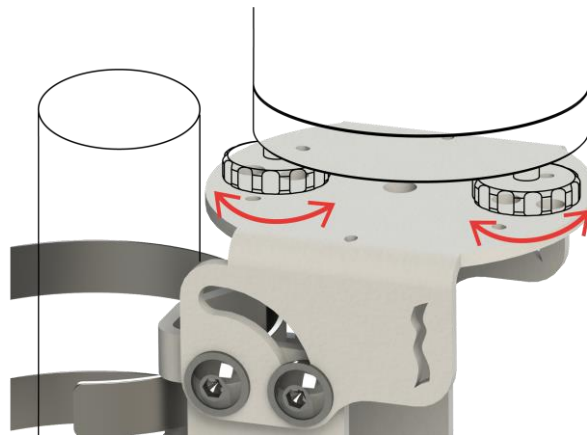

Figure 3.4.6 *Installation of PMF01 on a vertical mast, step 5*

3.5 Platform- or surface mounting installations

When mounting PMF01 on a surface or platform allowing the use of bolts, please follow the instructions below. Bolts for mounting PMF01 onto the surface are not included! The holes for the surface mount accept bolts up to M6.

1. Two holes have to be present in the surface, in order to install the bracket, 48 mm heart-to-heart distance.

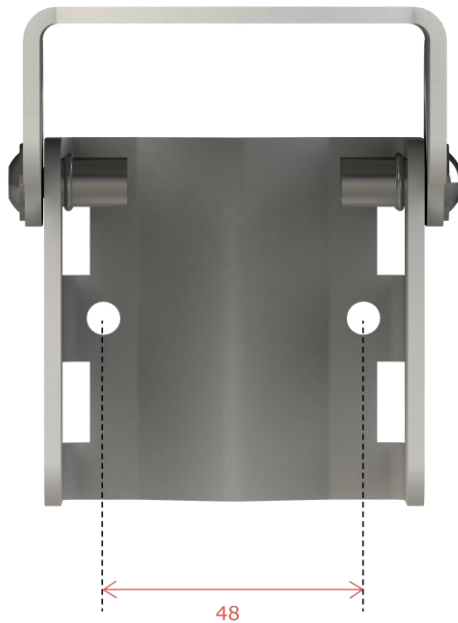

Figure 3.5.1 Installation of PMF01 on a surface, step 1

2. Open the bracket and install on the surface using dedicated bolts.

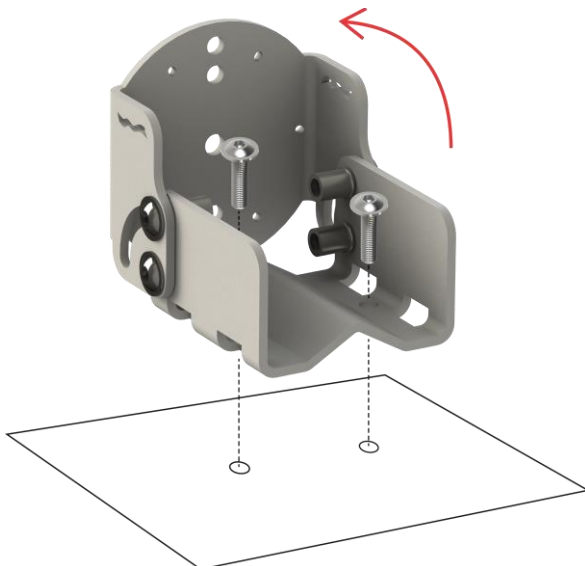

Figure 3.5.2 Installation of PMF01 on a surface, step 2

3. Tighten the bolts on the bracket (a) and install the sensor onto the bracket (b).

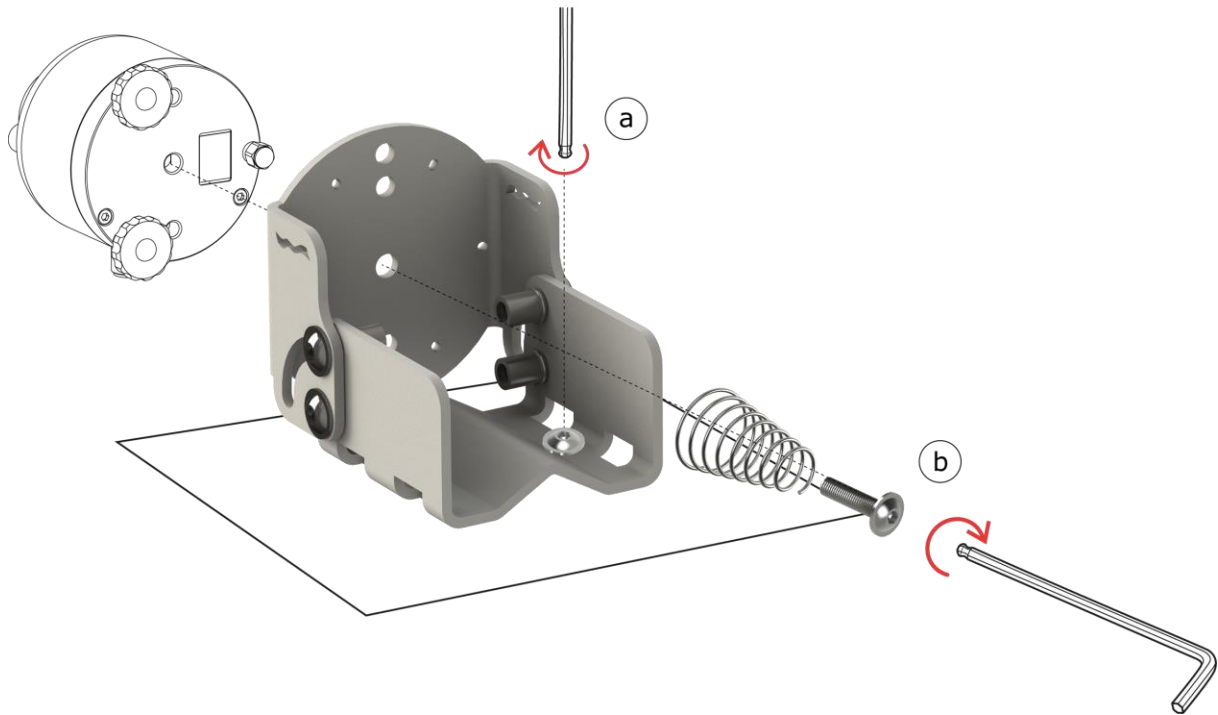

Figure 3.5.3 Installation of PMF01 on a surface, step 3

4. Level the sensor using the levelling feet. See the pyranometer user manual for further instructions, for example on installations of screen caps and cabling.

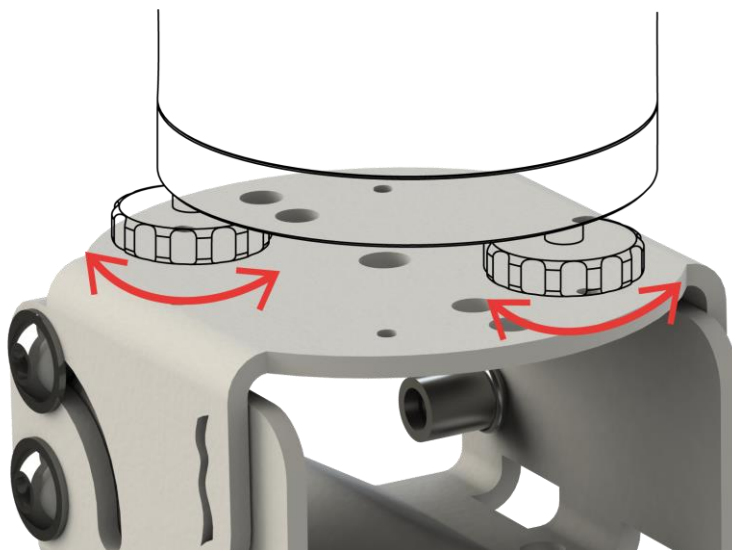

Figure 3.5.4 Installation of PMF01 on a surface, step 1

3.6 Tilted, Plane of Array (POA) mounting installations

When using PMF01 for the installation of tilted (POA) pyranometers, instead of in a horizontal orientation, continue to use the instructions below.

1. Prior to the Plane of Array setting, the sensor should be installed on the bracket and levelled, as described in Chapter 4.4.

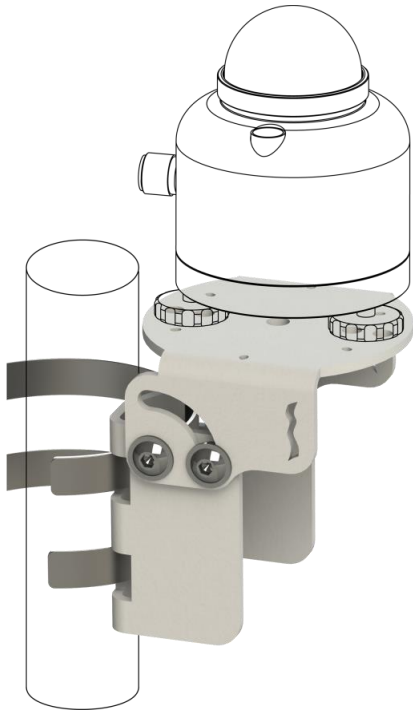

Figure 3.6.1 Installation of PMF01 in Plane of Array, step 1

2. Loosen bolts

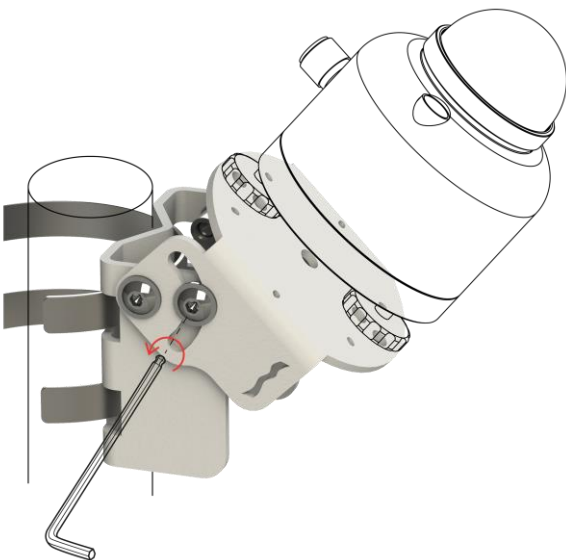

Figure 3.6.2 Installation of PMF01 in Plane of Array, step 2

3. Place the bracket into the desired tilted position

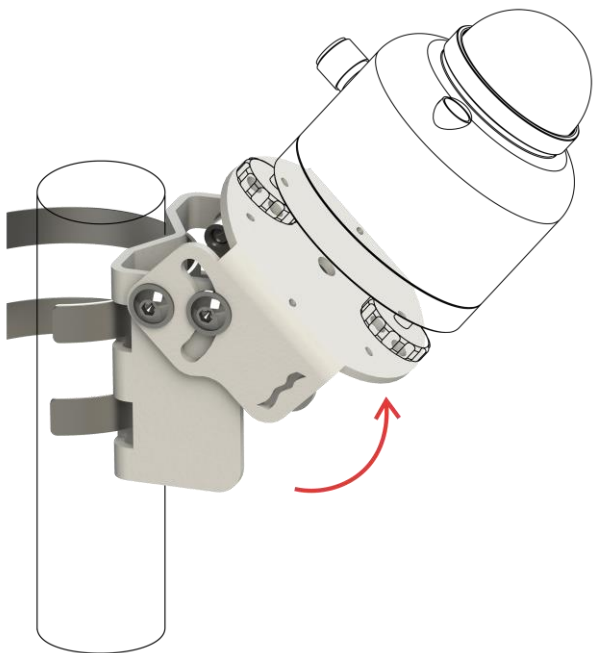

Figure 3.6.3 *Installation of PMF01 in Plane of Array, step 3*

4. Tighten bolts

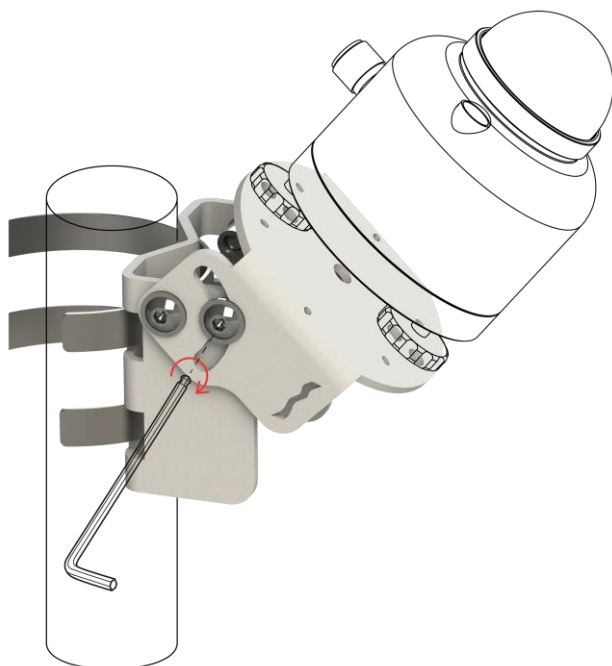

Figure 3.6.4 *Installation of PMF01 in Plane of Array, step 4*

4 Installation of PMF02

4.1 Site selection and installation

Please also refer to your pyranometer user manual for a proper installation of those particular pyranometers with PMF02 pyranometer mounting fixture. The instruments should be used in accordance with the recommended practices of ISO, IEC, WMO and ASTM.

4.2 GHI and tilted, Plane of Array (POA) mounting installations

When installing PMF02, please follow the instructions below:

1. Mount the bracket to a suitable fence or surface to which the two pyranometers are to be connected. Use two M6 (or smaller) bolts (not included with PMF02), fitting within the 6.3 mm width of the openings in PMF02 and suitable for use with the fence or surface.

Hukseflux recommends a bracket such as PMF02 not to be mounted directly to a PV panel or array mounting frame. Please consider the electrical grounding of the instruments.

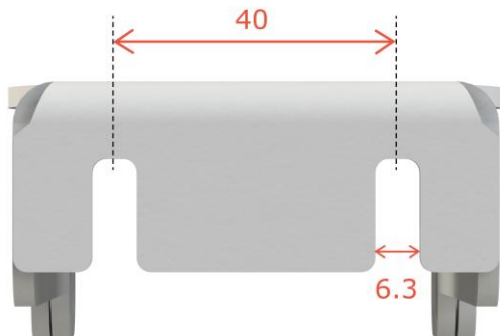

Figure 4.2.1 PMF02 dimensions in 10^{-3} m.

2. Ensure the bolts on the long sides of the bracket are tightened. Precise levelling and tilting is done later during the installation.
- 3a. Install the two sensors using the spring-loaded bolts: Attach the M6x25 bolt with the spring to the bracket and lock it using the M6 nut. Put the sensor onto the bolt, place the sensor feet in the designated holes. Turn the bolt further into the sensor bottom plate by using a 4 mm hex key. See Figure 4.2.2.
- 3b. When not following step 3a, follow step 3b instead for both sensors, using two M5 bolts per sensor. Place the sensor feet in the designated holes. Turn the bolts into the sensor through the bracket holes matching those of your pyranometer, and tighten the bolts using a 4 mm hex key.

4. Level both sensors using the levelling feet. See the pyranometer user manual for further instructions, for example on installations of screen caps and cabling.
5. Place the moveable POA part of PMF02 with its sensor into Plane of array. Once it is in the desired tilted position, tighten bolts on the long side of the bracket.

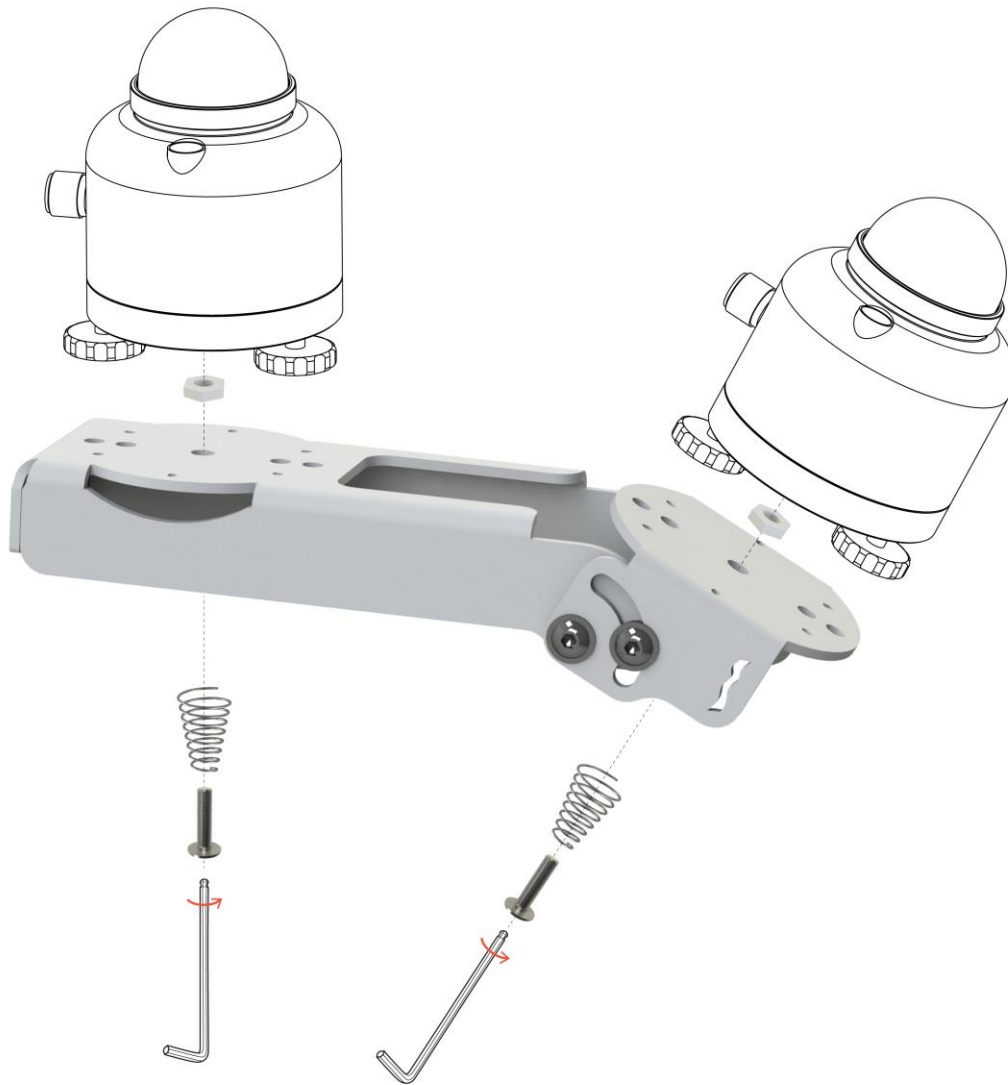

Figure 4.2.2 Installation of two pyranometers on PMF02 using the central spring-loaded bolts, step 3a

5 Installation of VMA01

5.1 Site selection and installation

Please also refer to your pyranometer and VU01 ventilation unit user manual for a proper installation of that particular ventilated pyranometer with VMA01 mounting adapter and PMF01. The instrument should be used in accordance with the recommended practices of ISO, IEC, WMO and ASTM.

5.2 GHI or tilted, Plane of Array (POA) mounting installations

When installing the ventilation mounting adapter VMA01, please follow the instructions below:

Besides the mounting adapter VMA01, PMF01, VU01 ventilation unit, a suitable pyranometer (SR20, SR22, SR25) and a set of tools (7 mm socket wrench, 4 mm hex key) is needed.

1. Install PMF01. See Chapter 3.
2. Mount VMA01 adapter plate onto PMF01 bracket using the two M5 bolts and nuts included with VMA01.



Figure 5.2.1 *Installation of the VMA01 mounting adapter plate on PMF01 bracket, step 2*

3. Install VU01 on the VMA01 adapter plate using the 2 M5 bolts and nuts included with VU01.
4. Complete the installation of VU01 and the levelling of the pyranometer in VU01, as laid out in the VU01 manual.
5. The combination PMF01 + VMA01 + VU01 ventilated pyranometer may now also be placed in a tilted, Plane of Array, position, following the instructions in Chapter 3.6.

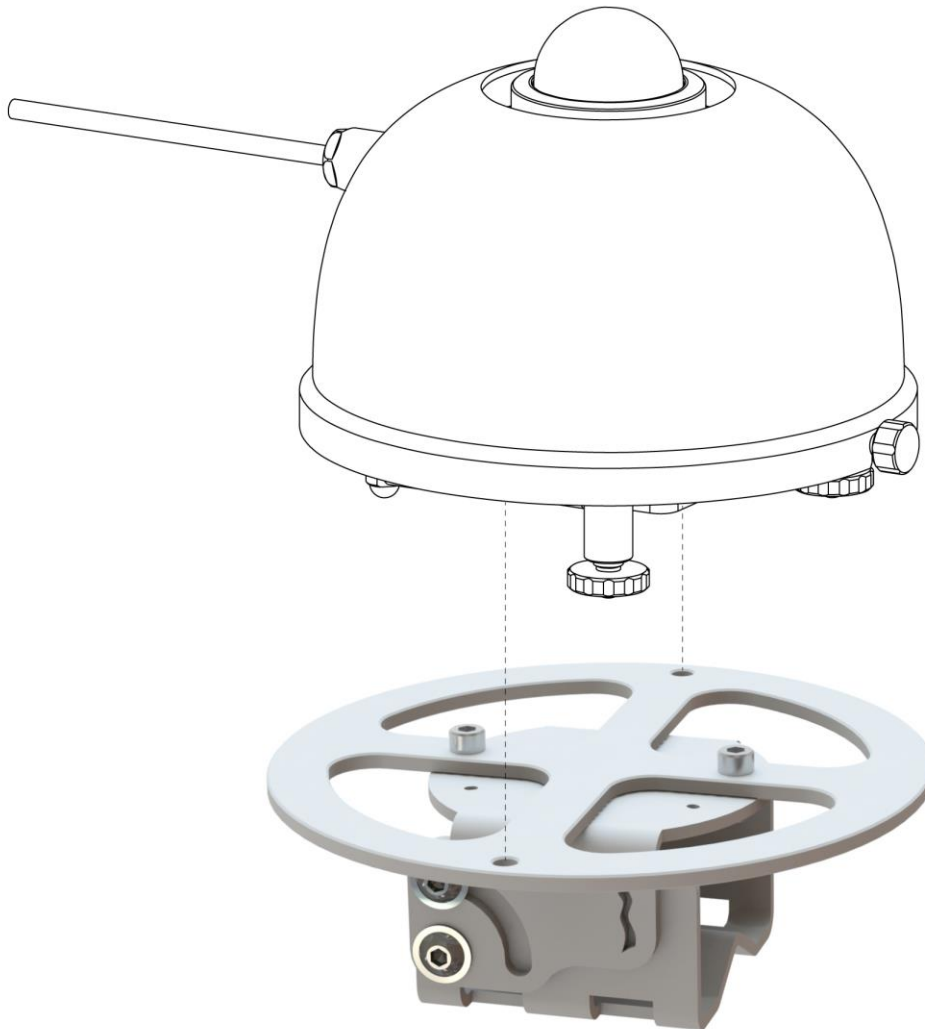

Figure 5.2.2 *Installation of VU01 on the VMA01 adapter plate using the 2 M5 bolts and nuts included with VU01, step 3.*

Please note: when opting for an installation with a downfacing ventilated pyranometer, (in other words in case of mounting VU01 upside down), make sure to cover the VMA01 plate, in order to prevent snow or rain to enter VU01's filter.

6 Appendices

6.1 Appendix on tools for PMF series

Table 6.1.1 *Specifications of tools for PMF series pyranometer mounting fixtures*

tooling required for PMF01	7 mm socket wrench
	4 mm hex key
tooling required for PMF02	7 mm socket wrench
	4 mm hex key
tooling required for VMA01	4 mm hex key

6.2 Appendix on spare parts for PMF series

- PMF01 bracket
- PMF02 bracket
- spring-loaded M6 bolt
- VMA01 mounting adapter

